

NOTE:

1. REFER TO ZONING BOARD CERTIFICATE FOR APPEAL NUMBER APPL#221-08 FOR CONDITIONS AFFECTING DEVELOPMENT OF THIS PARCEL.

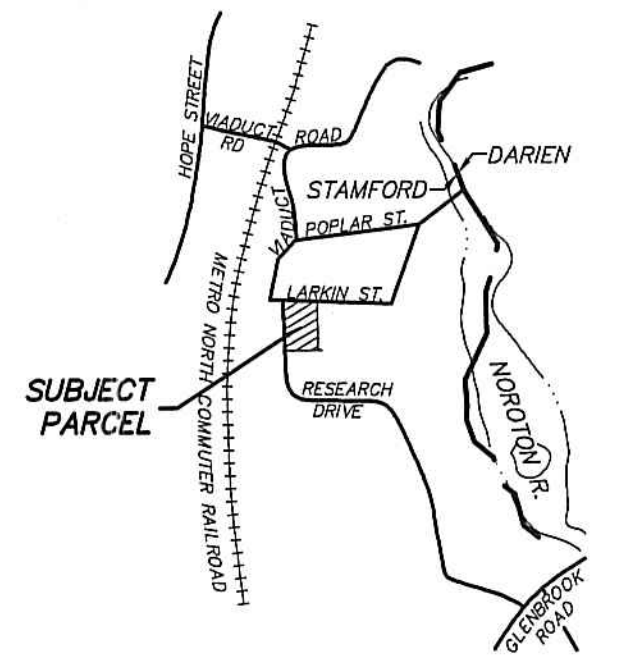

BUILDING COVERAGE
LOT AREA = 27,081 S.F.
DWELLING = 12,023 S.F.
TOTAL = 12,023 S.F.
PERCENT COVERAGE = 44.4%

MONUMENTATION

IPN O IRON PIN SET
NAIL O NAIL SET

LEGEND

GG GAS GATE
WM WATER GATE
WM WATER METER
UP UTILITY POLE
S SIGN
- - - APPROXIMATE LOCATION OF UNDERGROUND GAS SERVICE

UNDERGROUND UTILITIES HAVE BEEN PLOTTED FROM AVAILABLE INFORMATION, INCLUDING PHYSICAL EXPOSURE AND UTILITY COMPANY SKETCHES. DEPICTED UTILITIES ARE APPROXIMATE, AND ARE INCOMPLETE. SURVEY DECLARATION OF ACCURACY DOES NOT EXTEND TO THE PLOTTING OF UNDERGROUND UTILITIES. UNDERGROUND UTILITY LOCATION SHALL BE FIELD VERIFIED AND MARKED PRIOR TO COMMENCING ANY EXCAVATION ACTIVITIES. "CALL BEFORE YOU DIG," 1-800-922-4453.

THIS MAP IS AN IMPROVEMENT LOCATION SURVEY. BOUNDARY INFORMATION IS BASED ON A RESURVEY CONDUCTED IN ACCORDANCE WITH CLASS "A-2" HORIZONTAL ACCURACY AS DEFINED IN THE REGULATIONS OF CONNECTICUT STATE AGENCIES, SECTIONS 20-300b-1 THROUGH 20-300b-20.

PROPERTY LINES STAKED AS INDICATED ON NOVEMBER 15, 2021. ONLY COPIES OF THIS MAP, BEARING AN ORIGINAL IMPRINT OF THE SURVEYOR'S EMBOSSED SEAL SHALL BE CONSIDERED TO BE TRUE, VALID COPIES.

AREA = 27,081 S.F.
REFER TO MAP No. 4943 S.L.R.

LAND LIES IN "M-G" ZONING DISTRICT

TO MY KNOWLEDGE AND BELIEF, THIS MAP IS SUBSTANTIALLY CORRECT AS NOTED HEREON.

D'ANDREA SURVEYING & ENGINEERING, P.C.

Anthony L. D'Andrea, SURVEYOR
ANTHONY L. D'ANDREA CT. PE & LS No. 9673
RIVERSIDE, CONNECTICUT DECEMBER 29, 2021

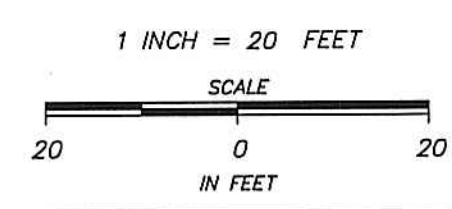

IMPROVEMENT LOCATION SURVEY
DEPICTING
12 RESEARCH DRIVE
STAMFORD, CONNECTICUT
PREPARED FOR
STAMFORD RESEARCH DRIVE LLC

February 8, 2022

Ms. Vineeta Mathur, AICP
Associate Planner
City of Stamford
888 Washington Boulevard
Stamford, CT 06901

**RE: FFD West LLC
12 Research Drive, Stamford, CT (the "Property")
Letter of Authority**

Dear Ms. Mathur:

FFD West LLC is a tenant of the Property pursuant to a long-term lease agreement with the owner of the Property, Stamford Research Drive LLC. I hereby authorize the attorneys of Carmody Torrance Sandak & Hennessey LLP, with offices located at 105 Washington Boulevard, Stamford, Connecticut, 06901, to act as agent for FFD West LLC in connection with all land use applications related to the redevelopment and use of the Property. Thank you for your acknowledgement of said authority.

Sincerely,

FFD West LLC

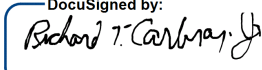
DocuSigned by:

By: 0D150F3B82C14F6...
FFD Holdings LLC, Managing Member

By: Richard T. Carbary Jr., duly
authorized Manager

February 8, 2022

Ms. Vineeta Mathur, AICP
Senior Planner
City of Stamford
888 Washington Boulevard
Stamford, CT 06901

**RE: Stamford Research Drive LLC
12 Research Drive, Stamford, CT (the "Property")
Letter of Authority**

Dear Ms. Mathur:

Stamford Research Drive LLC is an owner of the Property. I hereby authorize the attorneys of Carmody Torrance Sandak & Hennessey LLP, with offices located at 1055 Washington Boulevard, Stamford, Connecticut, 06901, to act as agent for Stamford Research Drive LLC in connection with all land use applications related to the redevelopment and use of the Property. Thank you for your acknowledgement of said authority.

Sincerely,

Stamford Research Drive LLC

DocuSigned by:

By: ECF248DA82A346C...
Eric Zachs, Manager

AERIAL IMAGE
12 RESEARCH DRIVE, STAMFORD, CONN.
Source: GoogleMaps

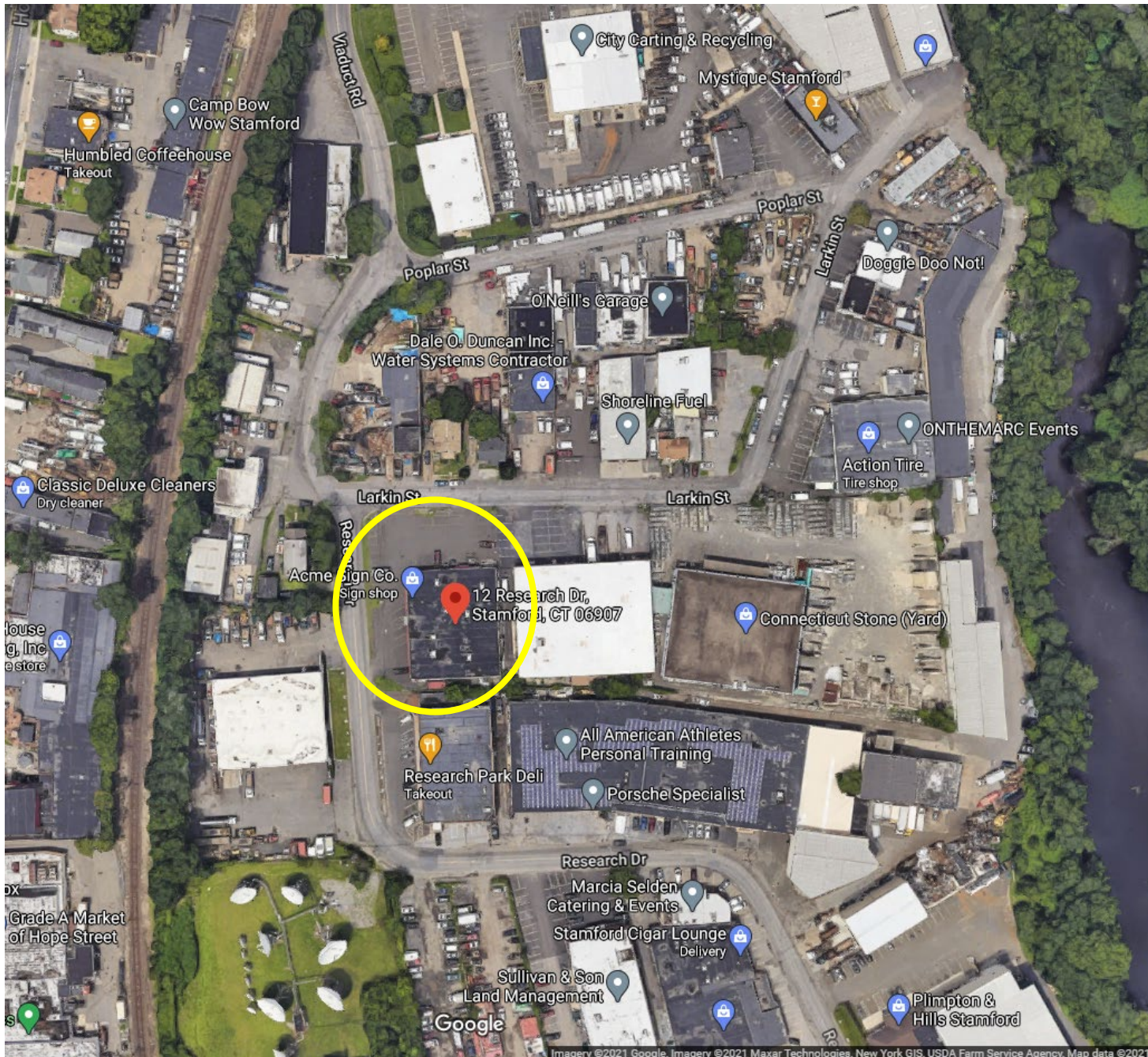

RESEARCH DRIVE

NOTE:
SEE A-0.5 FOR PLANTING
SPECS AND LOCATIONS

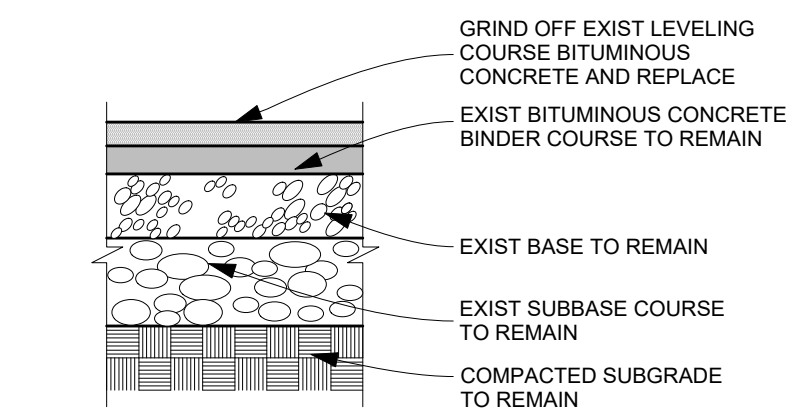
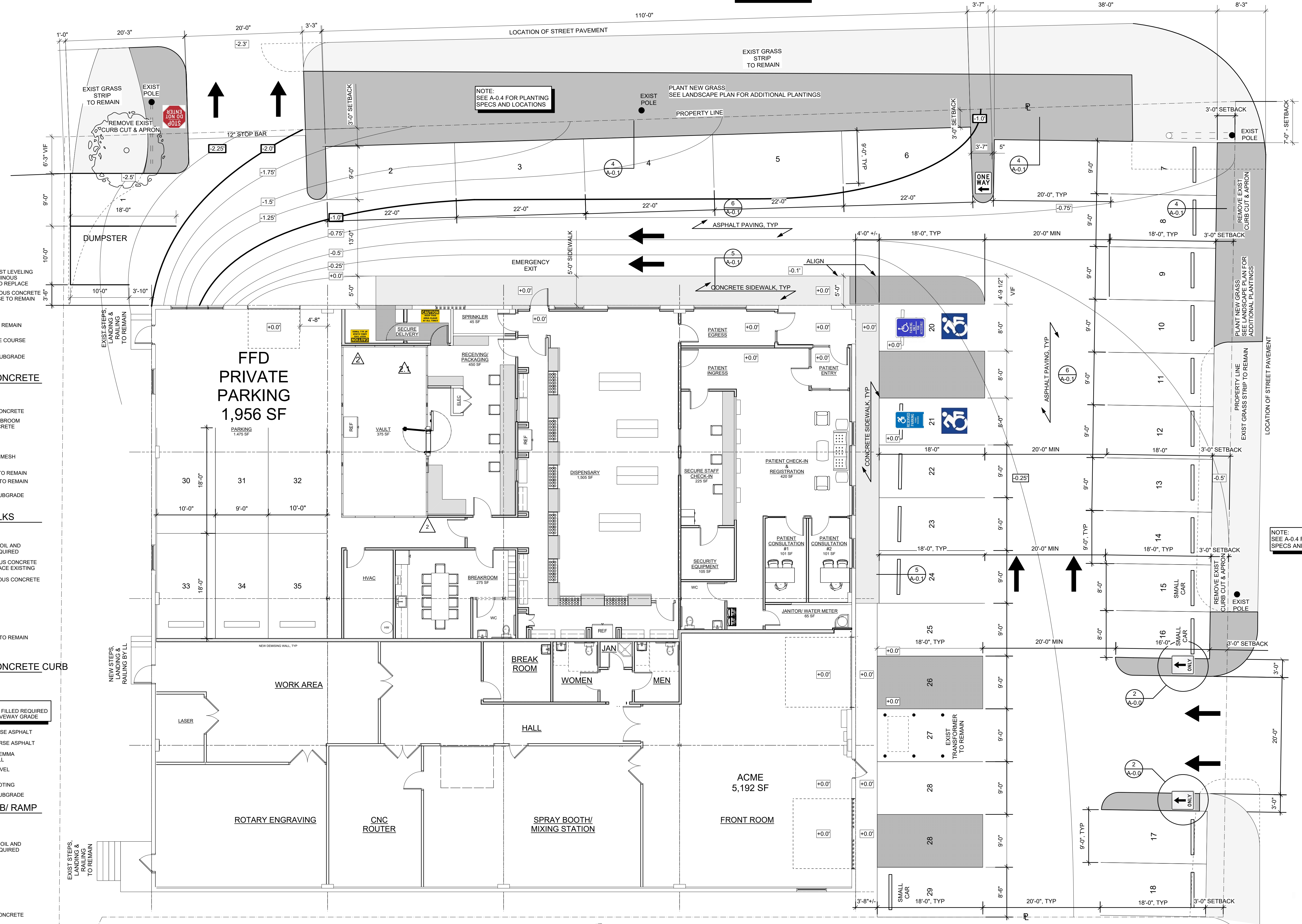
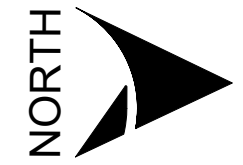

6 EXISTING BITUMINOUS CONCRETE
Scale: No Scale

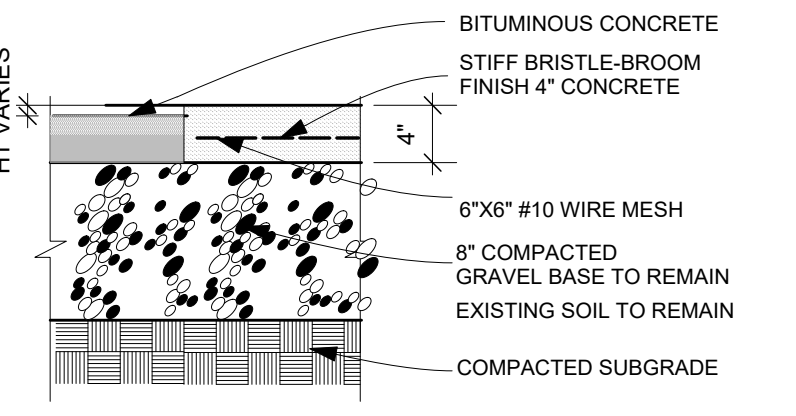

5 EXISTING CONCRETE WALKS
Scale: No Scale

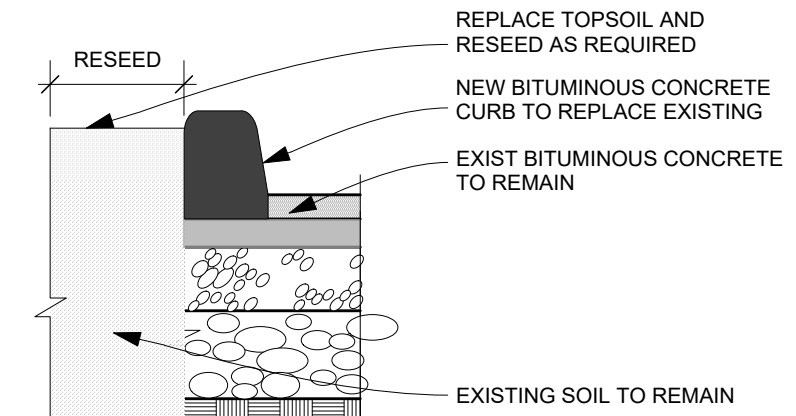

4 EXISTING BITUMINOUS CONCRETE CURB
Scale: No Scale

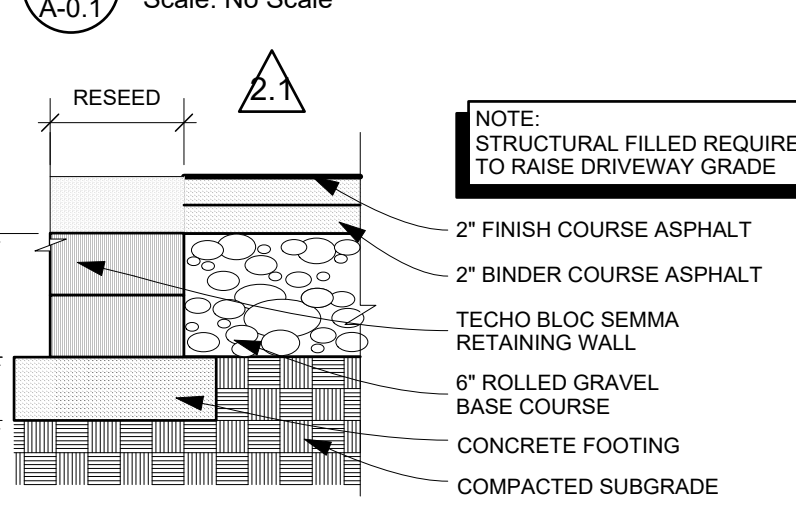

3 EXISTING CONCRETE SLAB/RAMP
Scale: No Scale

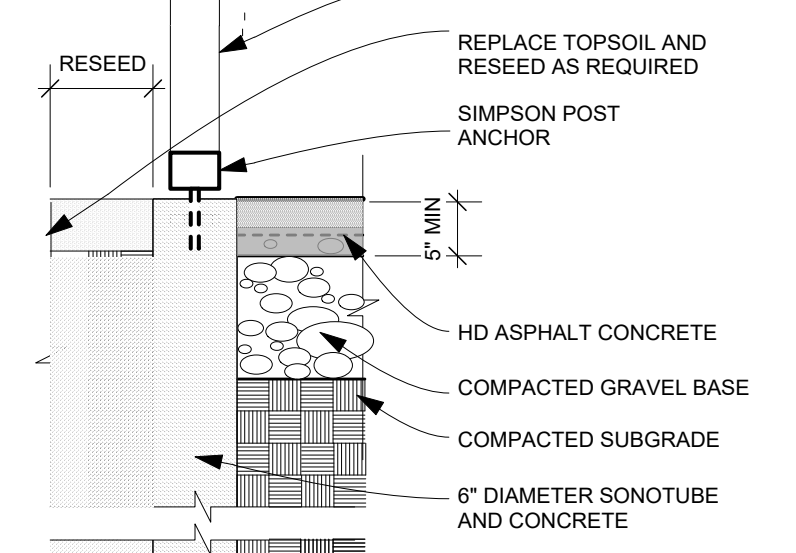

2 EXISTING FENCE POST ANCHOR
Scale: No Scale

1 EXISTING SITE PLAN
Scale: 1/8" = 1'-0"

ARCHITECT:
LARC ARCHITECTS
14 COLTON STREET
FARMINGTON, CT 06032
PH: (860) 313-6007
WWW.LARCARCHITECTS.COM
HILARY@LARCARCHITECTS.COM



12 RESEARCH DRIVE
STAMFORD, CT

SD:	1.31.2021
DD:	
CD:	
BID:	
PERMIT:	6.9.2021
CONTRACT:	
CONST:	
REVISION:	
1 - FFD GARAGE DOOR	6.29.2021
2 - FFD COMMENTS	8.11.2021
DOOR/HDWE SCHED, VAULT	8.26.2021
2.1 - DIMENSIONS, GRADING	10.7.2021
MISC DETAIL COORDINATION	10.28.2021
2.2 - SURVEY UPDATE	11.5.2021
2.3 - SURVEY UPDATE	11.10.2021
3.0 - AS BUILT	2.9.2022



EXISTING
SITE PLAN

A-0.1
R3.0



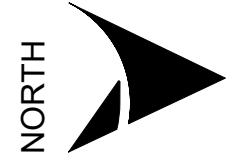

PROPERTY LINE

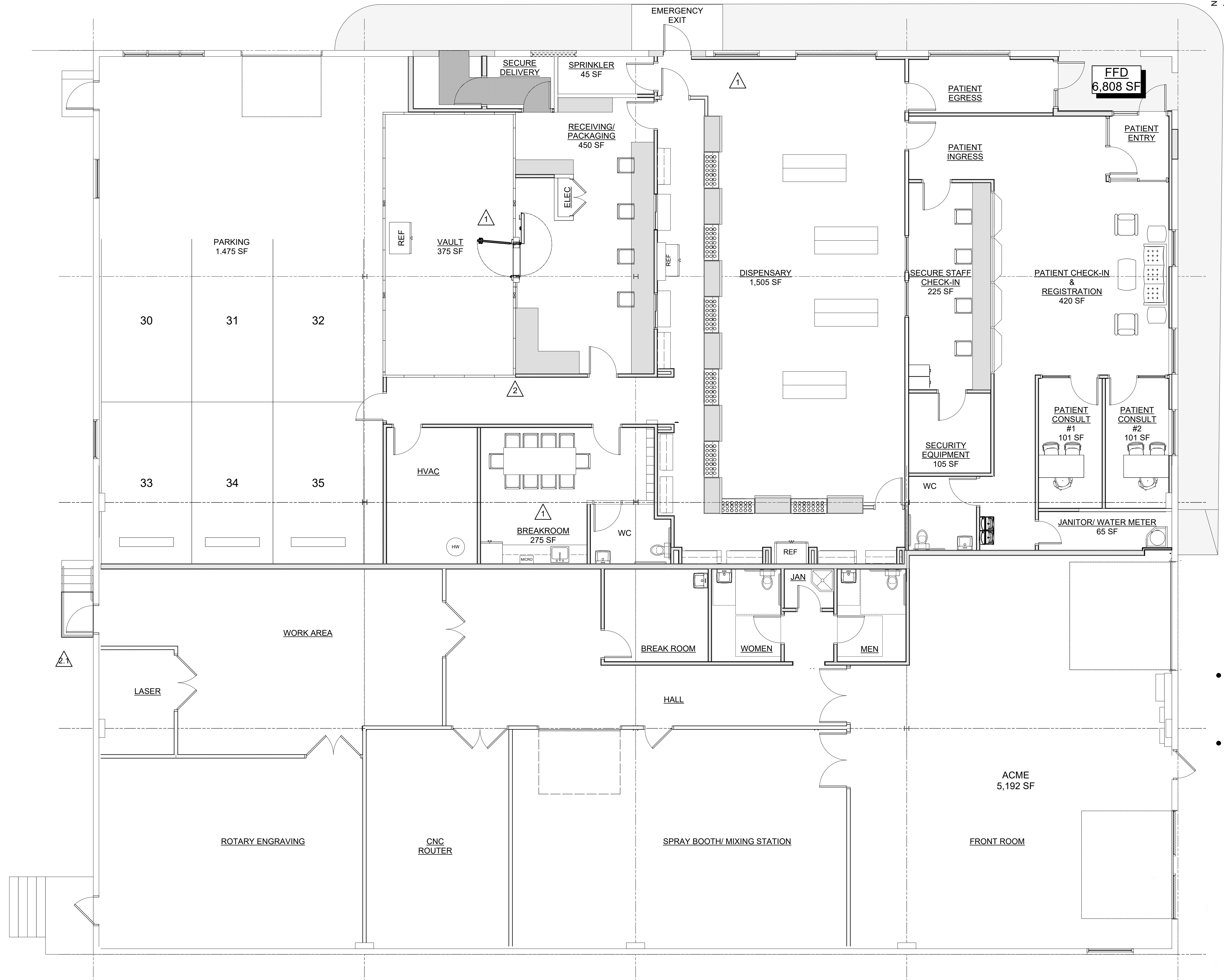

ARCHITECT
LARC ARCHITECTS
1000 STATE STREET
FARMINGTON, CT 06032
PH: (860) 338-9807
WWW.LARCARCHITECTS.COM
HLARY@LARCARCHITECTS.COM

FINE FETTER
DISPENSARY
12 RESEARCH DRIVE
STAMFORD, CT

SD:	1.31.2021
DD:	2.28.2021
RF:	
PERMIT:	6.8.2021
CONTRACT:	
CONRT:	

REVISION	
1 - FD COMMENTS	7.19.2021
2 - DOOR/HARDWARE SCHED	8.11.2021
2.1 - MISC DETAIL COORDINATION	10.28.2021
2.2 - DOOR 24 RELOCATED	12.15.2021
2.3 - FFD SF	1.17.2022
3.0 - AS BUILT	2.9.2022



EXISTING LAYOUT PLANS

1 EXISTING LAYOUT PLANS
A-1.0 Scale: 3/16" = 1'-0"

A-1.0
R3.0

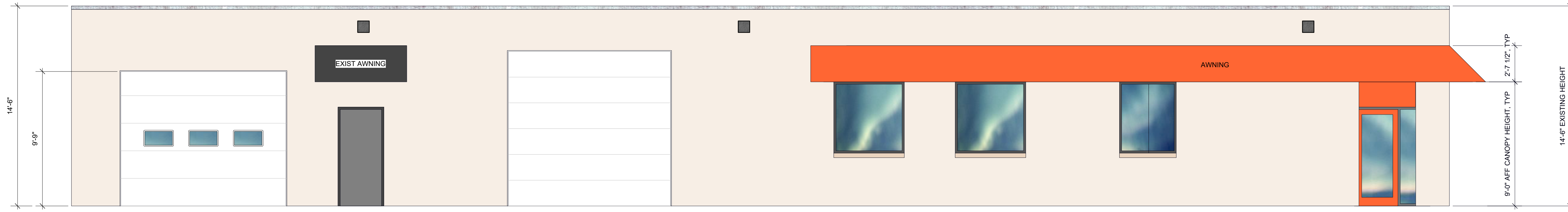

1 EXISTING NORTH ELEVATION
Scale: 1/4" = 1'-0"

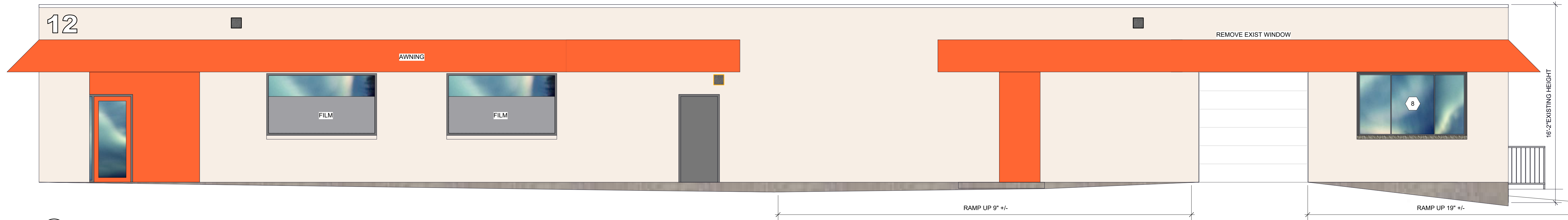

2 EXISTING EAST ELEVATION
Scale: 1/4" = 1'-0"

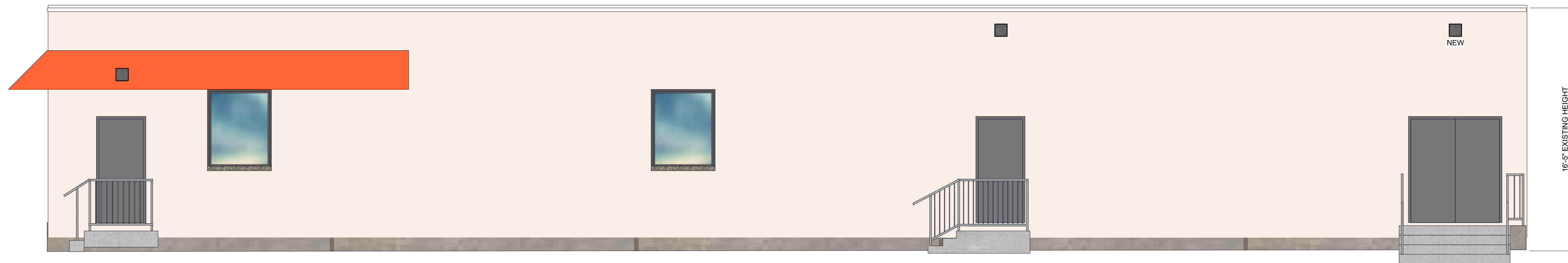

3 EXISTING SOUTH ELEVATION
Scale: 1/4" = 1'-0"

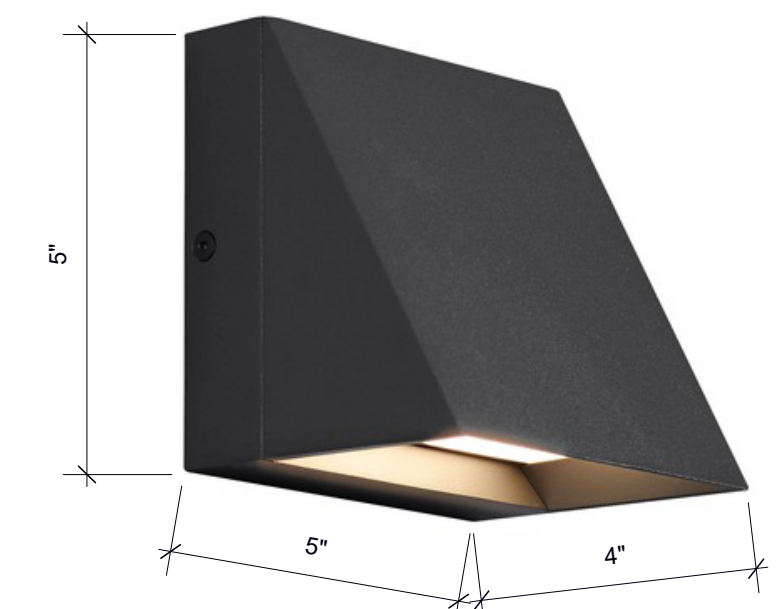

TECH LIGHTING
PITCH OUTDOOR LED WALL MOUNT
700WSPIT S H LED827
TYP ALL LOCATIONS (NEW & EXIST)

5 TYP EXTERIOR FIXTURE
A-2.0

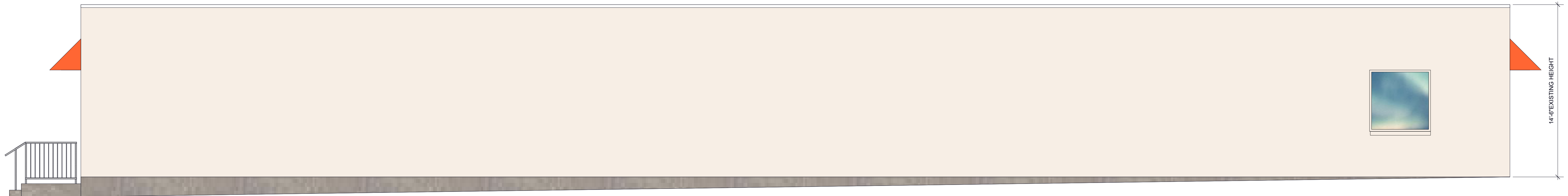

4 EXISTING EAST ELEVATION
Scale: 1/4" = 1'-0"

ARCHITECT:
LARC ARCHITECTS
14 COLTON STREET
STAMFORD, CT 06032
PH (860) 313-8807
SHELDON@LARCARCHITECTS.COM
HILARY@LARCARCHITECTS.COM

FINE FETTER DISPENSARY
12 RESEARCH DRIVE
STAMFORD, CT

SD:	1.31.2021
DD:	4.28.2021
CD:	
BID:	
PERMIT:	6.9.2021
CONTRACT:	
CONST:	

REVISION		
1 - FD COMMENTS	7.19.2021	
2 - DOOR HARDWARE SCHED	8.11.2021	
2.1 - SITE PLAN	8.11.2021	
2.2 - EXTERIOR LIGHTING	12.1.2021	
3.0 - AS BUILT	2.9.2022	



EXISTING EXTERIOR ELEVATIONS

A-2.0
R3.0

SD:	1.16.2021
DD:	
CD:	
BID:	
PERMIT:	
CONTRACT:	
CONST:	
REVISION	
R1 - SETBACKS, PARKING	2/25/21
FD COMMENTS	7/19/2021
R2 - DOOR HARDWARE SCHED	
FD COMMENTS	8/11/2021
VAULT	8/26/2021
R3 - AS BUILT	2/9/2022

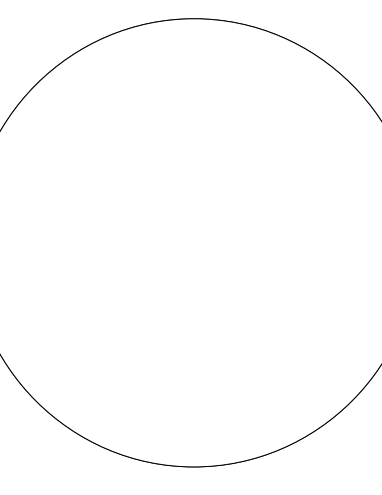

FFD EXISTING ADA PLAN & FFD EXISTING LIMITED ACCESS PLAN

A-0.5 R3

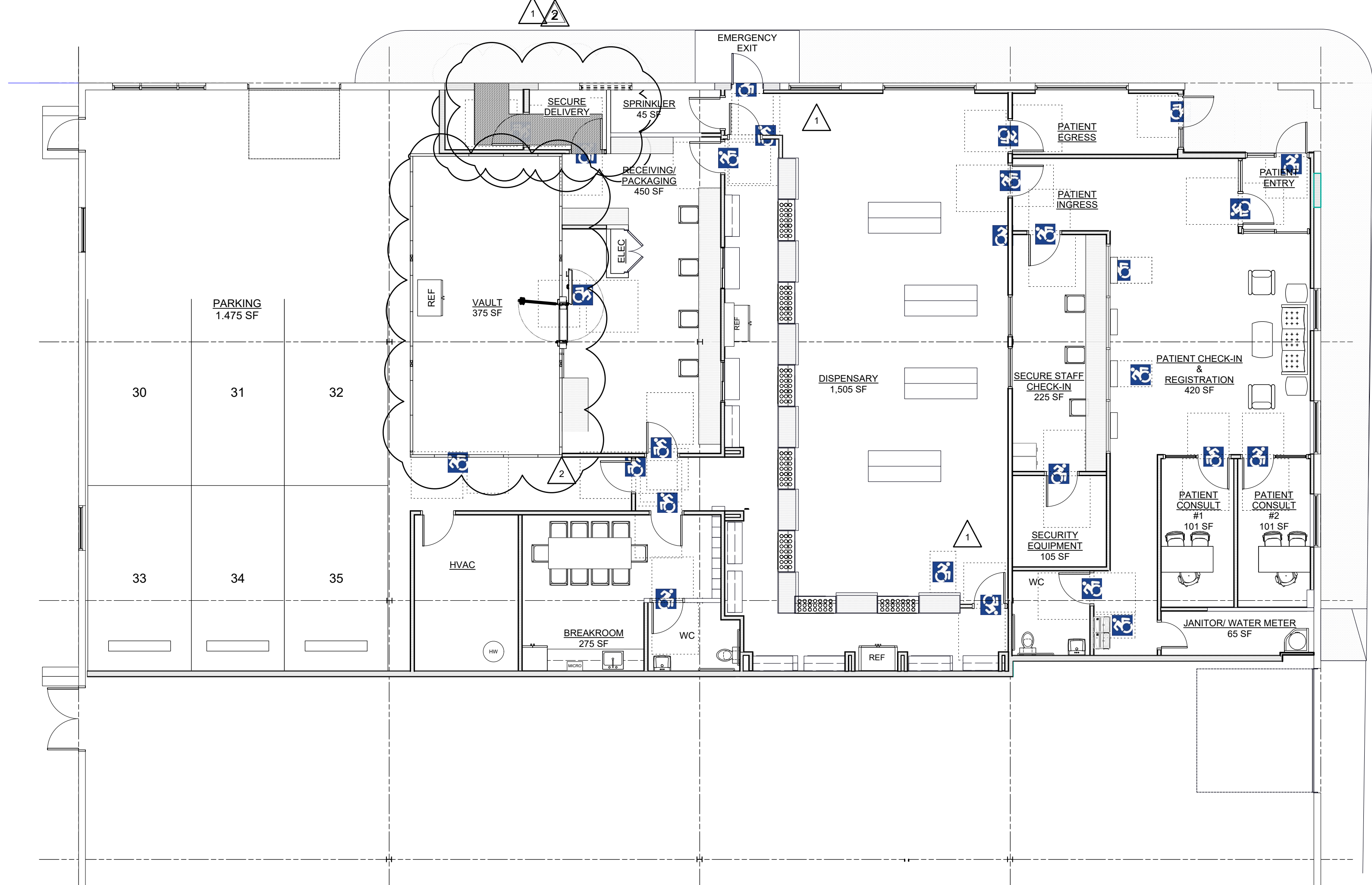

2 FFD - EXISTING ADA PLAN
A-0.5 Scale: 1/8" = 1'-0"

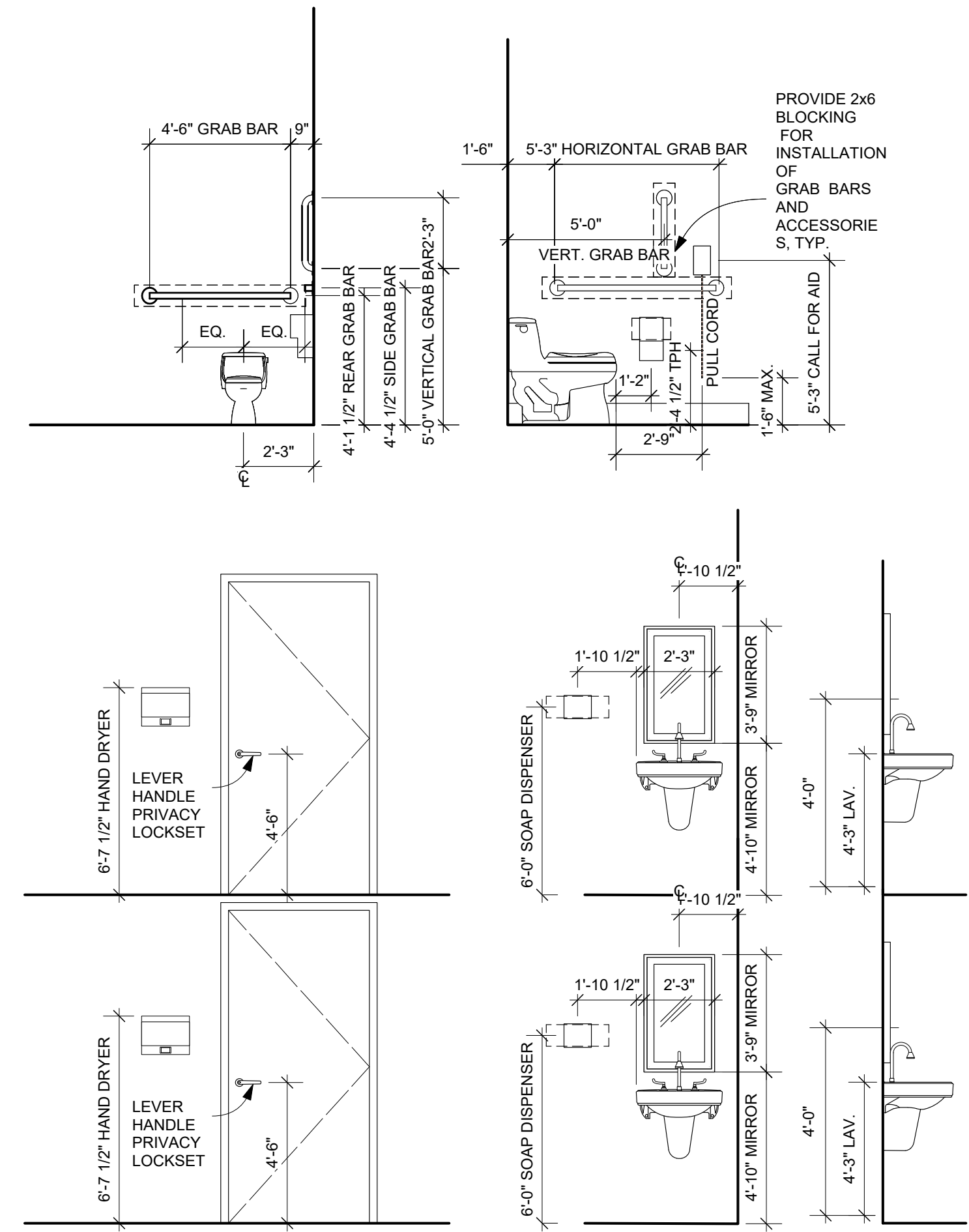

5 EXISTING ACCESSIBLE BATH DIMENSIONS
SD-4.3.3 Scale: 1/4" = 1'-0"

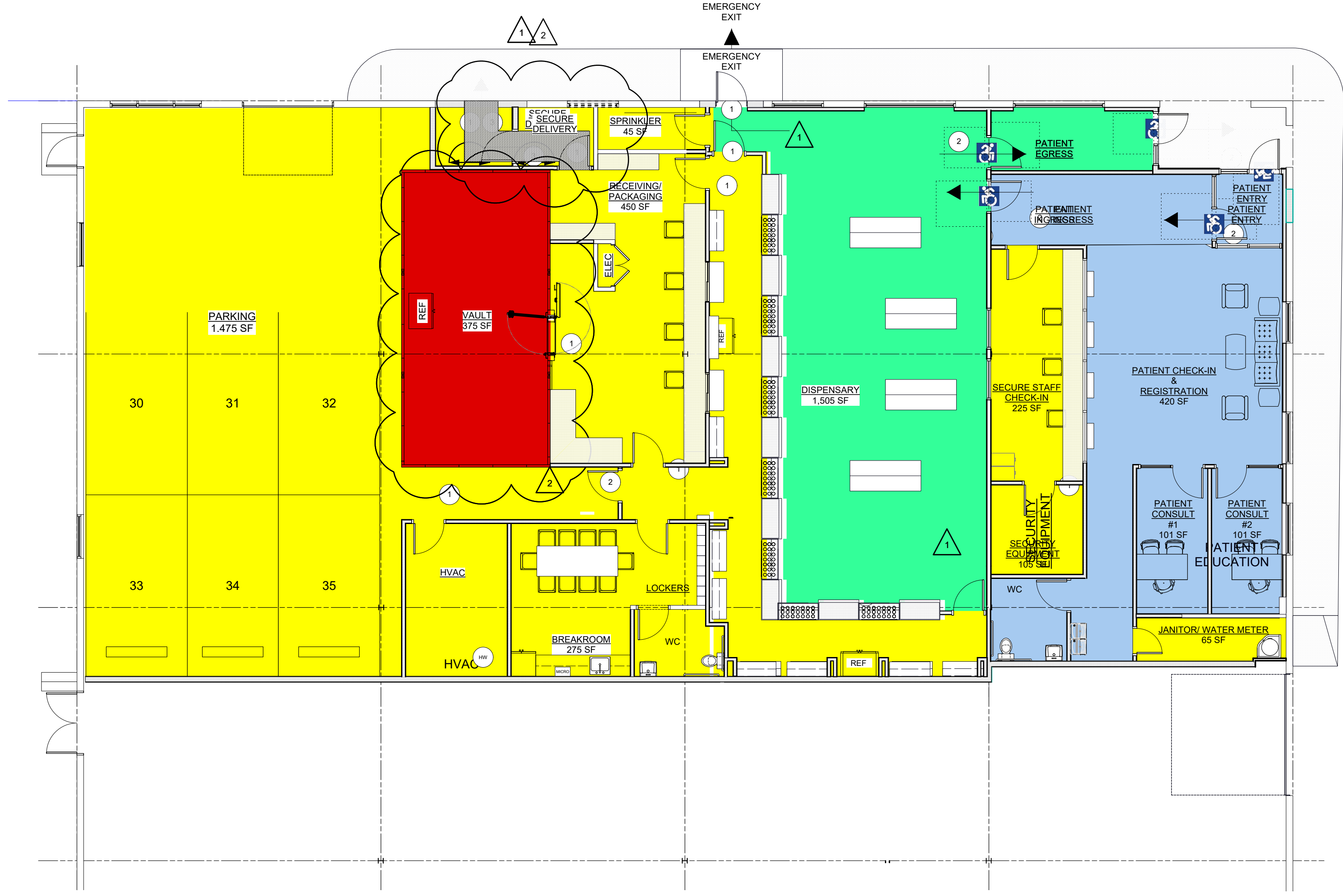

1 FFD - EXISTING LIMITED ACCESS PLAN
A-0.5 Scale: 1/8" = 1'-0"

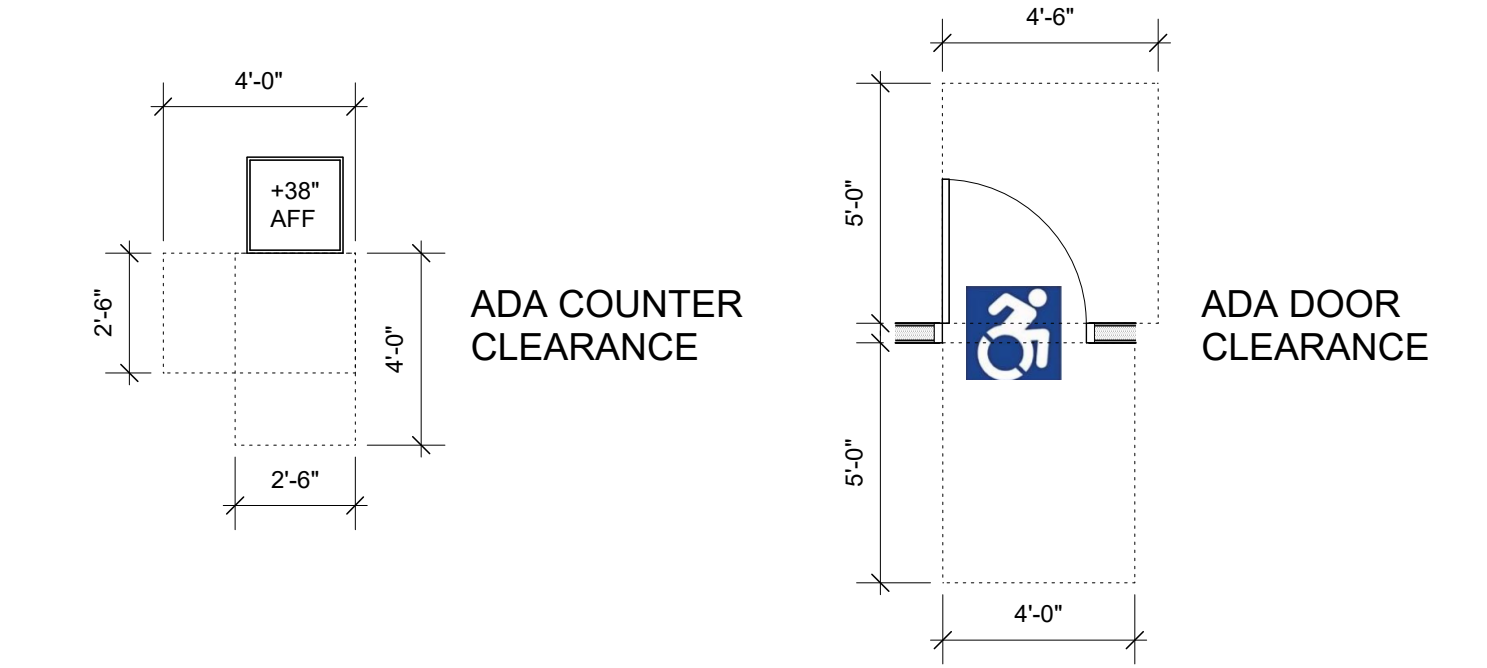

4 EXISTING ACCESSIBLE BATH DIMENSIONS
SD-4.3.3 Scale: 1/4" = 1'-0"

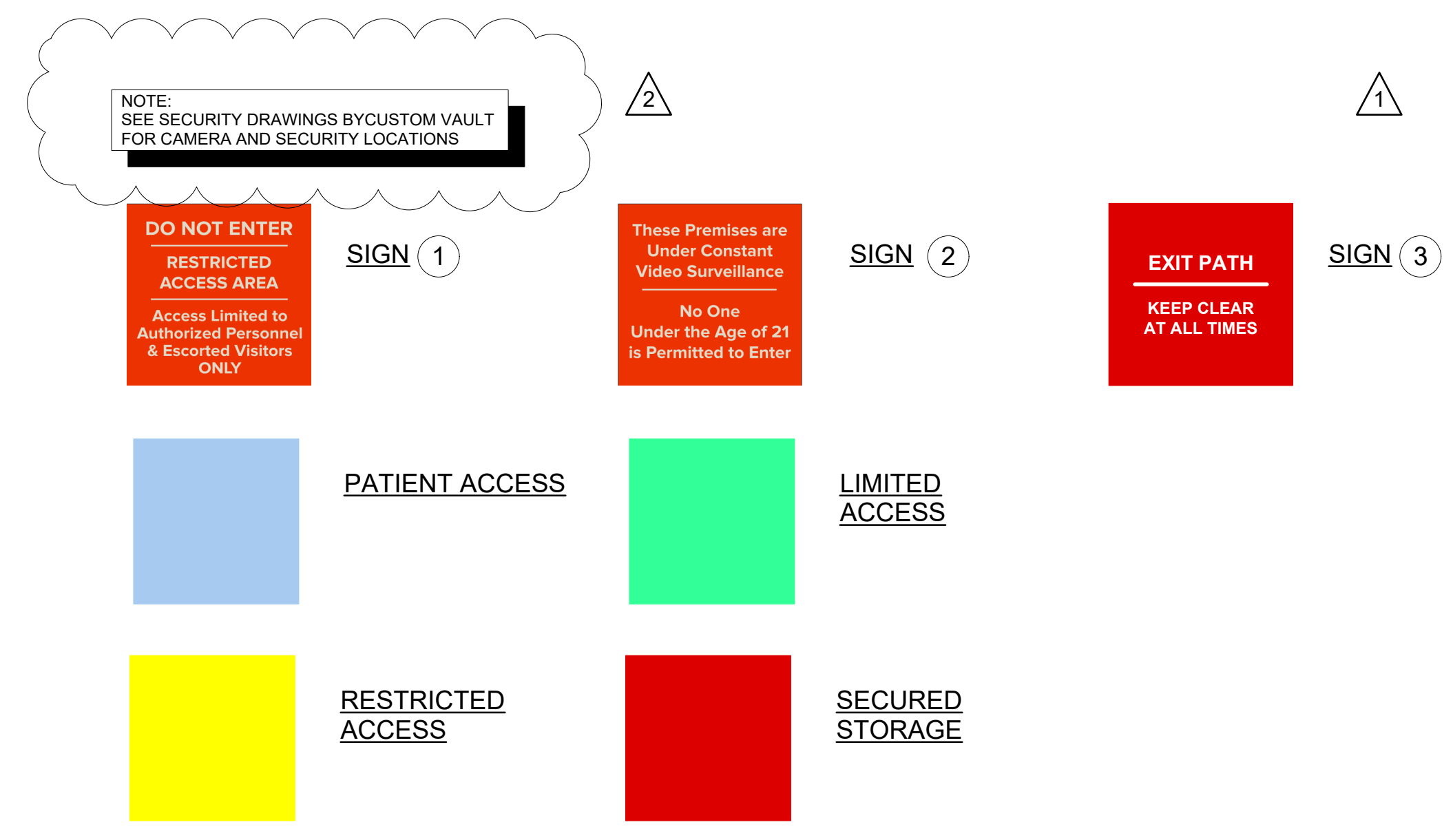

3 EXISTING SECURITY KEY
SD-4.3.3 Scale: 1/4" = 1'-0"



APPLICATION FOR SPECIAL PERMIT

Complete, notarize, and forward **thirteen (13) hard copies and (1) electronic copy in PDF format** to Clerk of the Zoning Board with a **\$1,000.00 Public Hearing Fee** and the required application filing fee (see **Fee Schedule** below), payable to the City of Stamford.

NOTE: Cost of required advertisements are payable by the Applicant and performance of required mailing to surrounding property owners is the sole responsibility of the applicant. **LAND RECORDS RECORDING FEE:** \$60.00 for First page - \$5.00 for each additional page)

Fee Schedule

Special Permit 20,000 sq. ft. or less	\$460.00
Special Permit more than 20,000 sq. ft.	\$460.00 + \$30 per 1,000 sq. ft. or portion thereof in excess of 20,000 sq. ft.

APPLICANT NAME (S): Stamford Research Drive LLC and FFD West LLC

APPLICANT ADDRESS: c/o Agent: Meaghan Miles, Carmody Torrance Sandak & Hennessey LLP, 1055 Washington Blvd, 4th Fl, Stamford, Connecticut 06109

APPLICANT PHONE #: c/o Agent: 203-425-4200

IS APPLICANT AN OWNER OF PROPERTY IN THE CITY OF STAMFORD? Yes

LOCATION OF PROPERTY IN STAMFORD OWNED BY APPLICANT (S): 12 Research Drive

ADDRESS OF SUBJECT PROPERTY: 12 Research Drive, Stamford, Connecticut

PRESENT ZONING DISTRICT: M-G

TITLE OF SITE PLANS & ARCHITECTURAL PLANS: See enclosed Schedule B.

REQUESTED SPECIAL PERMIT: (Attach written statement describing request)
Special Permit for a Hybrid Retailer pursuant to Sec. 5.E and Public Act 21-1. Please find enclosed Project Narrative and Statement of Findings.

LOCATION: (Give boundaries of land affected, distance from nearest intersecting streets, lot depths and Town Clerk's Block Number)
Please see Schedule A: Property Description.

NAME AND ADDRESS OF OWNERS OF ALL PROPERTY INVOLVED IN REQUEST:

<u>NAME & ADDRESS</u>	<u>LOCATION</u>
Stamford Research Drive LLC Newing LLC 40 Woodland Street Hartford, CT 06105	12 Research Drive, Stamford, CT

DOES ANY PORTION OF THE PREMISES AFFECTED BY THIS APPLICATION LIE WITHIN 500 FEET OF THE BORDER LINE WITH GREENWICH, DARIEN OR NEW CANAAN? No (If yes, notification must be sent to Town Clerk of neighboring community by registered mail within 7 days of receipt of application – PA 87-307).

DOES THE PROJECT RESULT IN THE CREATION OF 10 OR MORE UNITS OR 10,000 SF OR MORE IN FLOOR AREA OR DISTURBANCE OF 20,000 SF OR MORE IN LAND AREA, THROUGH NEW DEVELOPMENT, RECONSTRUCTION, ENLARGEMENT OR SUBSTANTIAL ALTERATIONS? No (If yes, then complete the Stamford Sustainability Scorecard per Section 15.F).



DATED AT STAMFORD, CONNECTICUT, THIS 8th DAY OF ~~January~~ February 2022

SIGNED: *Meaghan Miles*
Meaghan M. Miles

NOTE: Application cannot be scheduled for Public Hearing until 35 days have elapsed from the date of referral to the Stamford Planning Board. If applicant wishes to withdraw application, please notify the Zoning Board at least three (3) days prior to Public Hearing so that the Board may have sufficient time to publicize the withdrawal.

STATE OF CONNECTICUT
COUNTY OF FAIRFIELD ss STAMFORD February 8 2022

Personally appeared Meaghan Miles, signer of the foregoing application, who made oath to the truth of the contents thereof, before me.

[Signature]
Notary Public - Commissioner of the Superior Court

FOR OFFICE USE ONLY

APPL. #: _____ Received in the office of the Zoning Board: Date: _____

By: _____



Daniel S. Glissman
ATTORNEY AT LAW

daniel.glissman@mrglaw.com
TEL 860.278.1900
FAX 860.547.1191

February 10, 2022

Via E-Mail Delivery

City of Stamford
Land Use Bureau
Attn: Ralph Blessing
888 Washington Blvd., 7th Floor
Stamford, CT 06901

Re: 12 Research Drive, Stamford, CT 06907

Dear Mr. Blessing:

This office, and co-counsel Carmody Torrance Sandak & Hennessey LLP, represent FFD West LLC (d/b/a “**Fine Fettle**”) (the “**Applicant**”) in connection with the licensing and permitting of its proposed Hybrid Retailer¹ (the “**Facility**”) to be located at 12 Research Drive, Stamford, CT 06907 (the “**Property**”). Please accept this letter and its attachment as additional information for the Applicant’s request to amend its prior Special Permit approval to allow for the use of the Property as a Hybrid Retailer.

We note that Public Act No. 21-1 entitled “An Act Concerning Responsible and Equitable Regulation of Adult-Use Cannabis” (the “**Act**”), provides clear and unambiguous legislative instruction regarding a municipality’s authority to regulate cannabis establishments, which by definition includes a Hybrid Retailer. Specifically, Section 148(c) of the Act states that:

*“Unless otherwise provided for by a municipality through its zoning regulations or ordinances, a **cannabis establishment** shall be zoned as if for any other similar use, other than a cannabis establishment, would be zoned” (emphasis added).*

Pursuant to Section 148(c) of the Act, and because the City does not have a specific ordinance or bylaw governing Hybrid Retailers, these uses must be analogized with another similar use already in existence in the City’s zoning regulations (the “**Regulations**”). Analogizing the proposed Hybrid Retailer use to a similarly situated medical marijuana dispensary facility is an appropriate comparison. The definition of “cannabis establishment” in the Act specifically includes medical marijuana dispensaries (known as a “Dispensary Facility” in the Act and regulated pursuant to Section 420f of the Connecticut General Statutes). The proposed Hybrid Retailer use incorporates the original Medical Marijuana use previously approved by the City at the Property and adds adult use sales. The addition of adult use sales is a function of the legalization of adult use cannabis in Connecticut pursuant to the passage of the Act in July of 2021. Furthermore, analogizing the proposed use of a property to another similarly situated use permitted in the Regulations is not an unusual or uncommon practice in City.

The authority for the City’s Zoning Enforcement Officer (the “**ZEO**”) to interpret the Regulations is consistent with Connecticut law, and supported by numerous Connecticut court opinions giving deference

¹ Pursuant to Public Act. No 21-1, a Hybrid Retailer is defined as a “person that is licensed to purchase cannabis and sell cannabis and medical marijuana products.”

to local municipalities in the interpretation of their regulations. See, e.g., *Fedorich v. Zoning Board of Appeals*, 178 Conn. 610, 614, 424 A.2d 289 (1979) ("because the local authority is closer to the circumstances and conditions which create the problem and shape its solution, zoning authorities are given wide discretion in determining public need and the means of meeting it"); *Couch v. Zoning Commission*, supra, 141 Conn. 359 ("[t]he history of zoning legislation indicates a clear intent on the part of the General Assembly that, subject to certain underlying principles, the solution of zoning questions is for the local agencies"); *Megin v. Zoning Board of Appeals*, 106 Conn. App. 602, 607, 942 A.2d 511 (courts generally employ deferential standard of review to actions of zoning board), cert. denied, 289 Conn. 901, 957 A.2d 871" (2008) *Komondy v. Zoning Board of Appeals*, 127 Conn. App. 669, 682-83, 16 A.3d 741 (2011).

Given the clear and unambiguous language set forth in Section 148 of the Act, previous precedent set by the City, and because the Regulations allow for, and the Company was approved to operate, a Medical Marijuana Dispensary use at the Property (which by definition is a "Cannabis Establishment"), we respectfully submit that the proposed Hybrid Retailer (also by definition a "Cannabis Establishment") must be permitted under the existing Regulations subject the requisite special permit amendment approval from the Zoning Board. The determination of zoning compliance for the use of the Property for the Facility, following Zoning Board approval, is not only permissible, but required under the Act.

We note that the City would not be the first in Connecticut to issue such approvals. On August 11, 2021, Newington's Planning and Zoning Commission unanimously approved a special permit allowing Fine Fettle to operate as a Hybrid Retailer, permitting the sale of both medical and adult use cannabis, and on September 2, 2021, Windham's Planning and Zoning Commission issued a special permit for Fine Fettle to similarly operate its facility as a Hybrid Retailer. We have included copies of articles from the Hartford Business Journal as Exhibit A to this letter reporting on both events and note that the Newington Town Planner is specifically quoted saying that "nothing in the law prevents the Newington Planning and Zoning Commission from issuing said approval, or the applicant from seeking the same in preparation for applying for state licensure".

In summary, the Act makes it clear that absent existing municipal zoning regulations or ordinances, cannabis establishments shall be treated like any other similar use. Here, there are no zoning regulations in place that explicitly prohibit the proposed Hybrid Retailer use at the Property and the City has already availed themselves of the same zoning provision to approve a similar, and arguably nearly identical, cannabis use.

Thank you for your attention to this matter.

Very truly yours,

Daniel S. Glissman

Daniel S. Glissman, Esq.
Phone: 860-278-1900
Email: daniel.glissman@mrglaw.com

Exhibit A

August 12, 2021

Newington PZC approves medical cannabis dispensary for eventual recreational sales



Fine Fettle COO Benjamin Zachs during a remote meeting of Newington's Planning and Zoning Commission Aug. 11, 2021

By Sean Teehan

Newington's Planning and Zoning Commission provided an initial greenlight to medical cannabis dispensary Fine Fettle, as it pursues expanding its license and selling to Connecticut's forthcoming adult-use market.

In a public hearing Wednesday night, Town Planning and Zoning Commissioners unanimously approved a special permit allowing Fine Fettle — which also owns and operates medical dispensaries in Willimantic and Storrs — to operate in town as a "hybrid" cannabis retailer selling to the adult-use as well as the medical market. Commissioners, who noted Rick Carbray, CEO of the Newington dispensary, formerly served on Newington's Town Council, didn't ask any questions before approving the measure.

"My understanding of the law is the state will not be issuing licenses for some time, up until perhaps next spring," Newington Town Planner Renata Bertotti said. "[But] there is nothing in the law that prevents the Commission... from issuing them or them seeking an approval for their location in preparation for applying [for state licensure]."

The local approval is a necessary step for a business to convert a medical cannabis license to a hybrid one, or for new businesses to get final licensing. The state cannabis legalization statute allows medical cannabis businesses to submit applications to expand their licenses beginning Sept. 1, without applying through the lottery system.

ADVERTISEMENT

DCP-approved dispensary facilities that converted to hybrid retailers may open their premises to the general public and commence adult use cannabis sales 30 days after legal retail cannabis is available for purchase in Connecticut.

Headquartered in Hartford, Fine Fettle Dispensary Holdings LLC operates six facilities in Connecticut, Massachusetts and Rhode Island.

In his presentation to the Planning and Zoning Commission, Fine Fettle COO Benjamin Zachs went over the store's security measures, cannabis tracking system and other details. He said the town has been hospitable to the business since it began operating as a medical dispensary in 2019.

"We're incredibly honored and proud to be doing what we're already doing in Newington," Zachs said. "We've found the town to be an incredible partner... we're going to do this the right way if given the opportunity."

ADVERTISEMENT



Sign up for Enews

Most Popular

Sun Life Financial moving CT office, 300 employees to downtown Hartford

September 2, 2021

Windham approves Fine Fettle's recreational marijuana dispensary plan



PHOTO | CONTRIBUTED

By Sean Teehan

Medical cannabis retailer Fine Fettle Dispensary - Willimantic has received a special permit to begin selling marijuana to the adult-use recreational market, if approved by state regulators.

Windham's Planning and Zoning Commission has issued Fine Fettle a special permit to operate its West Main Street medical marijuana dispensary as a hybrid retailer that's allowed to sell to medical and recreational-use customers.

Fine Fettle will still need to get a license from the state before it can begin serving the recreational market.

Lawmakers in June legalized the recreational use of cannabis.

ADVERTISEMENT

"From day one, we built a facility we felt confident had the parking and structure to handle the influx of recreational customers without affecting the patient experience for our medical patients," Fine Fettle CEO Richard Carbray said.

Windham's decision comes after Newington planning and zoning officials greenlit Fine Fettle's medical dispensary in that town to transition to hybrid sales. It also comes the same week during which medical cannabis businesses may begin submitting applications to the state Department of Consumer Protection to expand their licenses to serve the adult-use market.

The local approvals from Newington and Windham are a necessary step for Fine Fettle to convert its medical cannabis dispensary licenses to hybrid ones. The state cannabis legalization statute allows medical cannabis businesses to submit applications to expand their licenses beginning Sept. 1, without applying through the lottery system.

DCP-approved dispensaries that convert to hybrid retailers may open their premises to the general public and commence recreational sales 30 days after legal retail cannabis is available for purchase in Connecticut.

Headquartered in Hartford, Fine Fettle Dispensary Holdings LLC operates six facilities in Connecticut, Massachusetts and Rhode Island.

ADVERTISEMENT

Following the zoning board decision, Windham Mayor Thomas DeVivo expressed support for Fine Fettle's effort to expand into the adult-use market, and for cannabis legalization's ability to direct tax dollars to municipalities.

"With the legalization of recreational cannabis in Connecticut, we hope Fine Fettle in Willimantic can open soon," DeVivo said. "The bill that sends a 3% tax to the town can do a lot of good for us."



Sign up for Enews

February 10, 2022

1055 Washington Boulevard
4th Floor
Stamford, CT 06901

VIA E-MAIL & HAND DELIVERY

Ms. Vineeta Mathur
Senior Planner
City of Stamford
888 Washington Blvd.
Stamford, CT 06901
vmathur@stamfordct.gov

**RE: Proposed “Hybrid Retailer” Cannabis Establishment
Planning Board Referral: Application for Special Permit Modification
12 Research Drive, Stamford, Connecticut (the “Property”)**

Dear Ms. Mathur:

I recently filed applications with the Zoning Board in connection with modifying their Special Permit for a medical marijuana dispensary (“Dispensary”) (**Appl. 221-08**) to permit a “hybrid retailer” cannabis establishment (“Hybrid Retailer”) at the Property. Pursuant to Public Act No. 21-1, a “hybrid retailer” operates as both a Dispensary and sells cannabis for adult recreational use.

The Property encompasses 27,081± SF (0.62) acres, is zoned General Industrial District (“M-G”), and is situated at the corner of Research Drive and Larkin Street in a predominantly industrial area of Glenbrook. The Property is currently improved with a 12,023± SF building (the “Building”) constructed in 1969. The current Special Permit permits use of 6,808± SF of the Building as a Dispensary. In connection with the proposed use of the Building as Hybrid Retailer, there is no proposed increase in retail area, and the approved sales area for the Dispensary will now provide for both medical and recreational cannabis sales. Additional details are provided within the enclosed materials.

In connection therewith, enclosed please find eight (8) copies of the following items:

- Application for Approval of Special Permit;
- Schedules to Applications as follows:
 - Schedule A: Property Description;
 - Schedule B: List of Plans;
 - Schedule C: Project Narrative;
 - Schedule D: Statement of Findings;
- Zoning Data Chart, dated February 10, 2022;
- Site and Architectural Plan set prepared by L’Arc Architects LLC, dated February 9, 2022 and titled as follows:

- A-0.1 R3.0 – “Existing Site Plan”
 - A-1.0 R3.0 – “Existing Layout Plans”
 - A-2.0 R3.0 – “Existing Exterior Elevations”
 - A-0.5 R3 – “FFD Existing ADA Plan & FFD Existing Limited Access Plan”
- Property Survey titled “Improvement Location Survey depicting 12 Research Drive, Stamford, Connecticut,” prepared by D’Andrea Surveying & Engineering P.C., dated December 29, 2021;
 - Property aerial photo;
 - Dispensary Security Plan; and,
 - Letter from Daniel S. Glissman, Esq., dated February 10, 2022, concerning regulation of “hybrid retailers” under Public Act No. 21-1.

I understand the Planning Board will be reviewing the enclosed Special Permit application. In connection therewith, I would ask that I, and other members of the development team, kindly be afforded the opportunity to address the Board by making a brief presentation at that time. I look forward to presenting this project to the Planning Board. In the interim, please let me know if you have any questions or require additional materials.

Sincerely,



Meaghan M. Miles

Enclosures

cc: Development Team

**SCHEDULE A
PROPERTY DESCRIPTION**

All that certain piece, parcel or tract of land, with the buildings and improvements thereon, situated in the City of Stamford in the County of Fairfield and State of Connecticut, bounded and described as follows:

NORTHERLY: 139.08 feet by Larkin Street;
EASTERLY and
NORTHEASTERLY: 208.07 feet by land now or formerly of George Goldman;
SOUTHERLY: 148.30 feet by land now or formerly of DeLeo Brothers
Development Corporation; and
WESTERLY: 199.65 feet by Research Drive.

Said premises being known and designated as Parcel #1 and Parcel #2, as shown and delineated on a certain map entitled "Map Prepared for George Goldman Stamford, Connecticut", now on file in the office of the town clerk of said Stamford and numbered 4943, reference thereto being had.

**SCHEDULE B
LIST OF PLANS**

Site and Architectural Plan set prepared by L'Arc Architects LLC, dated February 9, 2022 and titled as follows:

- A-0.1 R3.0 – “Existing Site Plan”
- A-1.0 R3.0 – “Existing Layout Plans”
- A-2.0 R3.0 – “Existing Exterior Elevations”
- A-0.5 R3 – “FFD Existing ADA Plan & FFD Existing Limited Access Plan”

Property Survey titled “Improvement Location Survey depicting 12 Research Drive, Stamford, Connecticut,” prepared by D'Andrea Surveying & Engineering P.C., dated December 29, 2021.

SCHEDULE C PROJECT NARRATIVE

I. THE PROPERTY

The applicant, Stamford Research Drive LLC (“SRD”), is the owner of real property known as 12 Research Drive, Stamford, Connecticut (the “Property”).¹ SRD leases the Property to the applicant FFD West LLC d/b/a Fine Fettle Dispensary–Stamford (“Fine Fettle” and collectively referred to with SRD as the “Applicants”).² The Property is located at the corner of Research Drive and Larkin Street in a predominantly industrial area of Glenbrook. It is approximately 27,081± SF (0.62 acres), zoned General Industrial District (“M-G”), and in Master Plan Category 13 (General Industrial). The Property is currently improved with a 12,023± SF building (the “Building”) constructed in 1969.³ An aerial image of the Property and surrounding area is included for reference.

On May 3, 2021, the Zoning Board issued Special Permit and Site/Architectural Plans and Requested Uses approvals (Appl. 221-08) to the Applicants to operate a Medical Marijuana Dispensary (“Dispensary”) in approximately 6,808± SF of the Building. The approved site plans contained modest modifications and upgrades to the site including revisions to the interior floor plan of the Building, an improved parking area and layout, and robust landscaping. Shortly thereafter, the Applicants obtained a Building Permit and a Certificate of Occupancy issued on February 7, 2022. The remaining 5,192± SF of the Building is used by ACME Sign Co. for the manufacturing and warehousing of signage.

II. THE PROJECT: “HYBRID RETAILER” ADULT-USE CANNABIS SALES

Effective July 1, 2021, the Governor signed Public Act No. 21-1,⁴ titled “An Act Concerning the Responsible and Equitable Regulation of Adult-Use Cannabis” (the “Cannabis Bill”), to permit and regulate the sale of cannabis in the State of Connecticut. The Cannabis Bill established the classification of “hybrid retailer,” defined as “a person that is licensed to purchase cannabis and sell cannabis and medical marijuana products.” In other words, a “hybrid retailer” operates as both a Dispensary and sells cannabis for adult recreational use.

Pursuant to Section 5.E of the Zoning Regulations and as required by Section 148(c) of the Cannabis Bill, the Applicants respectfully request to modify their Special Permit approval to operate a “hybrid retailer” cannabis establishment at the Property to provide both medical marijuana and recreational adult-use cannabis sales (a “Hybrid Retailer”).⁵ There is no proposed increase in retail area, and the approved sales area for the Dispensary will now provide for both medical and recreational sales.

Like Dispensaries, use of the Property as a Hybrid Retailer is heavily regulated by the State and a license is required from the Connecticut Department of Consumer Protection (“DCP”) to

¹The Property is co-owned by both Stamford Research Drive LLC and Newing LLC. Newing LLC is not an applicant but does consent to these applications.

²FFD West LLC is affiliated with SRD.

³According to Tax Assessor Field Card.

⁴June Special Session 2021, P.A. 21-1.

⁵Please see companion letter from Attorney Daniel S. Glissman, dated February 8, 2022, detailing why pursuant to the Cannabis Bill a “hybrid retailer” cannabis establishment is treated as a Dispensary for zoning purposes under the Stamford Zoning Regulations.

operate. Because the Property already has a license from DCP to operate as a Dispensary, FFD has a statutory right to convert its Dispensary license to a Hybrid Retailer license and pay the required fee. The conversion period opens in February 2022, and it is anticipated that DCP will issue a Hybrid Retailer license to operate at this Property shortly thereafter.⁶

II. BACKGROUND: FINE FETTLE DISPENSARY

Fine Fettle currently operates two adult-use and medical co-located dispensaries in Massachusetts (which legalized the recreational sale of marijuana in 2016). In addition, Fine Fettle operates medical marijuana dispensaries in Newington and Willimantic, Connecticut. Last year, the Applicants detailed Fine Fettle’s exemplary record to the Board concerning its operations of those Dispensaries, including the submission of letters of support from the leaders of both municipalities. Fine Fettle has received local zoning approval from both municipalities to convert those medical dispensaries to “hybrid retail” cannabis establishments.

Fine Fettle will implement the same sales, security, and parking management strategies that have proven successful at its hybrid facilities in Massachusetts. When designing and planning this facility, Fine Fettle prepared for ample register space, consultation space, and expedited operational plans to ensure no construction or changes would be required to handle the additional customer population in a recreational cannabis market. The facility has 360-degree camera coverage inside and out, other than restrooms and HIPAA-compliant consultation rooms. The facility in its hybrid capacity would still be managed by a licensed pharmacist and pharmacists will be on site, by law, at all open hours of operation. Fine Fettle’s existing facilities have received no compliance infractions and have received the highest average rating across rating companies (such as Google), with over 98% of all reviews being five stars. To ensure the safety of product, patients, customers and employees at all times, all Fine Fettle locations follow a strict and detailed security plan which includes, for example, 100% camera coverage both inside its walls and around its perimeter, 90-day backup footage supply, physical protocols such as cameras, vault construction, motion detectors, and procedural protocols. Fine Fettle, across all its locations, has zero incidents of diversion or theft.

III. DESCRIPTION OF SURROUNDING USES

The area surrounding the Property is zoned either M-G or Light Industrial (“M-L”) and contains a variety of industrial and commercial uses. Adjacent uses include NorthEast Electrical supply store, Asco P&H Supple tool store, Shoreline Fuel, Research Park Deli, and limited non-conforming residential properties.⁷ Nearby uses include City Carting & Recycling, fitness studios, a digital media company and auto body shops. The MetroNorth (New Canaan Line) train tracks are approximately 250 feet to the east of the Property. These train tracks, and adjacent industrial and commercial uses, separate the Property from residential neighborhoods. As a result, the active

⁶Only existing Dispensaries can covert to Hybrid Retailers under the statutory conversion framework. Otherwise, Hybrid Retailers must obtain a license through a lottery system which likewise opens to applicants in February. Hybrid retailers can sell cannabis to medical and non-medical consumers. Retail locations that sell only recreational cannabis (without a medical cannabis component) are defined in the Cannabis Bill as a “Retailers.” The location and number of “Retailers” is statutorily limited by municipal population. In Stamford, a maximum of 5 retailers are permitted with its current population.

⁷As stated in the Master Plan for Cat. 13: “It is recognized that in some existing industrial sectors of Stamford, residential and manufacturing/assembly/warehousing have long co-existed as neighborhood uses.”

industrial nature of the area and the physical separation from sensitive receptors limits exposure of the use to the public and children.

IV. DESCRIPTION OF PROPOSED DEVELOPMENT SITE

The Property consists of approximately 0.62± acres (27,081± SF) and is identified as 12 Research Drive (Account # 002-1884). The Property is a corner lot fronting on both Research Drive and Larkin Street. It is currently improved with a 12,023± SF building and approximately 35 parking spaces.

V. PROJECT OVERVIEW

The project proposes to convert the approved Dispensary space of the Building into a Hybrid Retailer, as follows:

- There is no proposed increase in retail space; in other words, the retail area approved in connection with the Dispensary will remain unchanged. That area will now service both medical patients and provide recreational sales.
- Operations will continue to prioritize medical marijuana patients. Medical patients will have four dedicated registers that will be available only for medical patient purchases. When arriving at the facility, medical patients will also have an expedited check-in line and a window dedicated for faster check in to the facility, confirming their medical patient status. Per law, patients will have first access to product via the state's current producers, ensuring an ample supply of medication.
- The use is heavily regulated by the State of Connecticut. Staff will be experienced professionals licensed by the State of Connecticut to dispense recreational and medical marijuana.
- Adult-use customers will be verified for 21+, per the Cannabis Bill. Adult use customers will be checked while waiting in line, then again at the check in window of the dispensary. Adult-use customers will have dedicated registers.
- Point of sale tracking and inventory management will continue, which shall include:
 - All acquisitions, dispensing, and sales of marijuana, which will all be logged into the Medical Marijuana Program Tracking System and Adult-use Cannabis Tracking System on a real time basis.
 - All dispensing and sales transactions, including ensuring that such sales (i) are to registered qualifying patients, primary caregivers, authorized purchasers and verified customers above the age of 21, pursuant to the Cannabis Bill and (ii) adhere to the limits for usable marijuana in accordance with the Medical Marijuana Program and the Cannabis Bill.
- Because the size of the retail space is not changing, there is no change to the required number of parking spaces. The approved parking area provides thirty-five (35) spaces where twenty-

eight (28) are required, with eight (8) spaces reserved for ACME Sign Co. during weekdays. Fine Fettle also installed bike racks for employees and is offering \$200 per month to any employee who uses public transportation, bikes, or carpools more than 50% of workdays. In its initial opening period, FFD plans to contract with a third-party parking company to assist with all traffic and parking maintenance to aid in any potential traffic disruption. If public safety services are needed to manage site demand in the first thirty (30) days after opening, the Cannabis Bill authorizes the City to charge FFD up to \$50,000 for such costs incurred.⁸

- The facility will maintain the Security Plan approved by DCP for the Dispensary, titled “Theft and Diversion Prevention Plan,” encompassing 60 pages, that includes parameters for the following:
 - Security leadership (page 2);
 - Inventory control system and auditing (pp. 3-5);
 - Waste disposal procedures and storage (pp. 5-6);
 - Employee policies (pp. 6-9);
 - Employee training and management (pp. 9-11);
 - Reporting events (pp. 9-12);
 - Recordkeeping (pp. 12-14);
 - Dispensary facility diversion prevention (p. 15);
 - Emergency evacuation and response plan (pp. 15-18);
 - Interior signage (pp. 18-19);
 - Dispensing reporting and errors (pp. 19-21);
 - Exterior security (pp. 21-25);
 - Access control (pp. 25-36);
 - Video monitoring system (pp. 36-42);
 - Alarm system (pp. 42-46);
 - Receiving (pp. 46-51);
 - Storage (pp. 51-54);
 - Cash plan (pp. 54-56);
 - Information security (pp. 56-58);
 - Community policy (pp. 58-59);
 - Biannual review of security policies and procedures (pp. 59-60).
- The hours of operation will be seven (7) days a week, 9:00 a.m. to 8:00 p.m.⁹
- Deliveries will be handled the same way as approved for the Dispensary:
 - All deliveries will occur in an enclosed, single purpose receiving area that is not visible to the public, which will also function as a “man trap” preventing unauthorized persons from entering the facility through the back or side entrance.
 - Only properly vetted and verified personnel carrying valid identification documents, who are also escorted by security personnel, will be granted entry into the receiving area, for

⁸Specifically, pursuant to Sec. 83(d) of the Cannabis Bill, “[f]or up to thirty days after the opening of a retailer or hybrid retailer, a municipality may charge such retailer or hybrid retailer for any necessary and reasonable costs incurred by the municipality for provision of public safety services in relation to such opening, including, but not limited to, public safety costs incurred to direct traffic, not to exceed fifty thousand dollars.”

⁹Hybrid Retailers are required to maintain a minimum of thirty-five (35) hours of operation (presumably to ensure a high level of availability for medical patients).

the limited time necessary to perform duties. Under no circumstances will such persons be granted access to other portions of the facility.

- Approximately eight (8) deliveries a week are anticipated; deliveries typically occur during the following hours: 8:00am – 5:00pm.
- ACME Sign Co. will continue to serve as tenant in 5,143± SF of the Building. ACME uses the Building for the manufacture and warehousing of signage. They have approximately six (6) employees. As depicted on the enclosed site plan, eight (8) parking spaces will be reserved for ACME’s exclusive use. Their standard operating hours are Monday-Friday 8:00 AM – 4:00 PM. Outside of its standard operating hours, its parking will be available to dispensary customers.

VI. CONFORMITY OF SITE PLAN WITH THE M-G ZONING REGULATIONS AND THE CITY OF STAMFORD MASTER PLAN

In passing the Cannabis Bill, the Legislature recognized that sales of recreational adult-use cannabis can provide significant revenue to the State and municipalities with little impact on the local community. This Property is a perfect location for hybrid cannabis sales in Stamford. The purpose of the M-G zoning district is to allow a variety of industrial uses to operate in the City while separating them from susceptible uses and minimizing any potential negative impacts. In accordance with and furtherance of the goals of Master Plan Category 13, the M-G zone also permits a myriad of commercial and retail uses, including Dispensaries with Special Permit approval, which until recently was the only permitted form of cannabis sales in the State. This proposed project will further these objectives and benefit the neighborhood. The Property is not a prominent location and is surrounded by uses that characterize the M-G industrial zone. As a result, the Property is an ideal location for a Hybrid Retailer as it is in an area that is separated from susceptible and sensitive sites, such as schools, parks, and established residential neighborhoods. Moreover, the proposed use will increase the City’s tax base, and will further the economic development of this area of Stamford by attracting new customers.

VII. ACTIONS NECESSARY TO FACILITATE DEVELOPMENT

To facilitate permitting of this project, the Applicant has filed applications to modify its Special Permit approval. Specifically, the Applicant is seeking approval of the following specific requests:

- Special Permit approval pursuant to Section 5.E of the Stamford Zoning Regulations, as modified by Public Act No. 21-1, to operate a “hybrid retailer” cannabis establishment for the sale of recreational and medical marijuana.

SCHEDULE D STATEMENT OF FINDINGS

The specific Special Permit request detailed in Schedule C is integral to the development project as a whole. Thus, for purposes of demonstrating compliance with the standards and conditions below, the entire development proposal is considered.

A. Statement of Findings in Accordance with Section 19.C.2 of the Zoning Regulations

In accordance with Section 19.C.2 of the Zoning Regulations, the Applicant submits that the following standards and conditions have been satisfied:

Special Exceptions shall be granted by the reviewing board only upon a finding that the proposed use or structure or the proposed extension or alteration of an existing use or structure is in accord with the public convenience and welfare after taking into account, where appropriate:

1. *The location and nature of the proposed site including its size and configuration, the proposed size, scale and arrangement of structures, drives and parking areas and the proximity of existing dwellings and other structures.*

The Property is an ideal location in Stamford for a Hybrid Retailer. It is in the heart of an industrial zone and surrounded by a variety of industrial and commercial uses. It is far removed from sensitive receptors including schools, parks, and residential neighborhoods; moreover, it is further separated from such uses by train tracks and an established commercial corridor. The proposed use activates an industrial/commercial site that has been underutilized for some time, with a use that will provide increased tax revenue for the City of Stamford. Thus, the Applicant submits that the proposed building, including its proposed use, is appropriate for the surrounding neighborhood and this project is in accord with the public convenience and welfare.

2. *The nature and intensity of the proposed use in relation to its site and the surrounding area. Operations in connection with special exception uses shall not be injurious to the neighborhood, shall be in harmony with the general purpose and intent of these Regulations, and shall not be more objectionable to nearby properties by reason of noise, fumes, vibration, artificial lighting or other potential disturbances to the health, safety or peaceful enjoyment of property than the public necessity demands.*

The Property is in the M-G zone which is the most intense industrial zone in Stamford, and Master Plan Category 13, which contemplates a myriad of commercial and industrial uses. The proposed use is a retail use which is significantly less intense than other uses in the surrounding area and uses that are permitted as of right in the M-G zone. The proposed use poses no risk to nearby properties by reason of noise, fumes, vibration, artificial lighting or other potential disturbances to health, safety or peaceful enjoyment of property (particularly when contrasted against the risk of such nuisance factors created by existing surrounding uses and other permitted industrial uses). In addition, the Applicants' past experience with Hybrid Retailers in Massachusetts indicates this use is safe and secure, quiet, and a successful business that gives back to the community. In fact, studies from

across the country conclude that areas around dispensaries have less crime than they did prior to the opening of the dispensary, both medical and recreational. The project maintains the existing building, which is in harmony with the height and scale of surrounding buildings. Thus, the Applicant submits that the proposed development is appropriate for the neighborhood and will not be objectionable to nearby properties.

3. *The resulting traffic patterns, the adequacy of existing streets to accommodate the traffic associated with the proposed use, the adequacy of proposed off-street parking and loading, and the extent to which proposed driveways may cause a safety hazard, or traffic nuisance.*

Fine Fettle expects a level of site activity similar to that of its existing hybrid retailers in other states. There will typically be twelve (12) to fifteen (15) employees at a time, and approximately eight (8) deliveries a week. The use is comparable to that of most retail uses that would operate in a similar 12,000± SF building, and similar to existing operations in the area, and as such would not have an adverse impact on resulting traffic patterns. Thus, the Applicant submits that the area streets are more than adequate to support this project and traffic patterns should not be impacted. Likewise, an appropriate level of off-street parking is provided, as more parking spaces are provided than the number required under the zoning regulations for the proposed use.

If there is unusually high demand when the store initially opens, the Applicants will implement parking and traffic management measures to minimize any impact on the area, including an outsourced and professional parking management firm at its own expense. It has also offered employees \$200 per month to any employee who choose to carpool, cycle, or use public transportation for over 50% of his/her/their workdays in a given month. If public safety services are needed in the first thirty (30) days after opening, the Cannabis Bill authorizes the City to charge FFD up to \$50,000 for such costs incurred.

4. *The nature of the surrounding area and the extent to which the proposed use or feature might impair its present and future development.*

The proposed use is in harmony with the variety of industrial and commercial uses that surround the Property. In addition, the proposed use is safe and secure, quiet, and historically successful in other States, thereby having the potential to serve as a catalyst for further economic growth in the surrounding area and the provision of significant tax revenue (3% gross revenue) to the City of Stamford. The Property's location within the M-G zone and Master Plan Category 13 make this an ideal use for the Property.

5. *The Master Plan of the City of Stamford and all statements of the purpose and intent of these regulations.*

The Property is located in Master Plan Category 13 (General Industrial). The purpose of this category is to provide for and protect existing industrial development and preserve opportunities for new industrial uses, such other uses that are ancillary or subordinate to industrial activities, as well as promote their maintenance and viability. A Hybrid Retailer is an active and secure use, with little to no impact on the neighborhood, that will not

adversely affect industrial development; rather, the historic economic success of this use encourages further development and improvements to the area.

Accordingly, the proposed use is in accordance with the public convenience and welfare. The Applicant proposes to replace an underutilized industrial/commercial building with an active and secure commercial use, with corresponding economic benefits to the neighborhood. This project will increase the tax base and significantly improve this area of Stamford.

B. Statement of Findings in Accordance with Section 5.E of the Zoning Regulations

In accordance with Section 5.E of the Zoning Regulations governing medical marijuana dispensaries, the Applicant submits that the following standards and conditions have been satisfied:

- a. *Medical Marijuana Dispensaries must possess a current license from the State of Connecticut Department of Consumer Protection and comply with the Regulations of the State of Connecticut Department of Consumer Protection Concerning the Palliative Use of Marijuana, per the Connecticut General Statutes, Section 21a-408-1 to 21a-408-70, inclusive, as may be amended from time to time. Failure to maintain proper licenses shall be deemed an immediate violation of the City of Stamford Zoning Regulations.*

Like Dispensaries, use of the Property as a Hybrid Retailer is heavily regulated by the State and a license is required from the Connecticut Department of Consumer Protection (“DCP”) to operate. FFD will acquire and maintain all required licenses from DCP to operate a Hybrid Retailer facility at the Property. Because the Property already has a license from DCP to operate as a Dispensary, FFD has a statutory right to convert its Dispensary license to a Hybrid Retailer license and pay the required fee. The conversion period opens in February 2022, and it is anticipated that DCP will issue a Hybrid Retailer license to operate at this Property shortly thereafter.

- b. *No Medical Marijuana Dispensaries shall be located within a 3,000 feet radius of any other Dispensary;*

While this provision is specific to Dispensaries, the Applicants note that the only other medical marijuana dispensary in Stamford is located at 814 East Main Street. That site is 2.1 miles from the Property (or approximately 11,088 feet). This proposed Hybrid Retailer will be the first retailer of recreational adult-use cannabis in the City, and the Applicants submit that this industrial park is an ideal location in the City for such sales in addition to medical marijuana.

- c. *Signage for Dispensaries must comply with the following standards: (1) Signage shall be limited to a single Sign no larger than sixteen inches in height by eighteen inches in width; (2) There shall be no illumination of a Sign advertising a marijuana product at anytime; (3) There shall be no signage that advertises marijuana brand names or utilizes graphics related to marijuana or paraphernalia on the exterior of the Dispensary or the Building in which the Dispensary is located; (4) There shall be no display of marijuana or*

paraphernalia within the Dispensary which is clearly visible from the exterior of the Dispensary; and (5) There shall be no signage which advertises the price of its marijuana.

The Board previously approved a signage plan that complies with these provisions. Additionally, any and all windows looking into the facility are 100% opaque in allowing site lines into the facility, whether into areas that hold marijuana or not.

- d. Parking shall be provided according to Section 12 of the Zoning Regulations, as follows: A Dispensary shall meet the parking standard for Retail Store.*

The proposed parking complies with Section 12 of the Zoning Regulations for a retail store. Specifically, the retail space area is 4,852± SF (including back of house areas). Assuming this entire area was used for retail, 20 spaces are required, and 27 are provided specifically for Fine Fettle. An additional eight (8) parking spaces are reserved for the other tenant of the building, ACME Sign Co.

Fine Fettle



THEFT AND DIVERSION PREVENTION PLAN

Mission and Goals

The Dispensary Facility recognizes the impact a marijuana Dispensary Facility may have on the surrounding community and businesses, and the Dispensary Facility has developed a plan to minimize any concerns. The Theft and Diversion Plan serves to safely facilitate the sale of marijuana in accordance with the highest standards for quality of products, services, and public safety with the ultimate goal of alleviating symptoms of debilitating health conditions that warrant the administration of marijuana. The Dispensary Facility will position itself as an industry security leader by working with the medical community to further improve security policies and procedures and will serve as a model for other marijuana businesses.

The Dispensary Facility seeks to prevent theft, loss, and diversion to ensure the continuous security of all marijuana at the dispensary, while providing a safe and secure environment for all Dispensary Facility Employees, visitors, primary caregivers, and qualifying patients. Every aspect of the Dispensary Facility's operation will have a strong emphasis on security and prevention of unlawful activity, including the diversion of marijuana.

Per Section 21a-408-34(f), only a Dispensary may dispense marijuana, and only a Dispensary or Dispensary Technician may sell marijuana, to qualifying patients and primary caregivers who are registered with the department pursuant to the Act and section 21a-408-6 of the Regulations of Connecticut State Agencies. A Dispensary Technician may assist, under the direct supervision of a Dispensary, in the dispensing of marijuana.

Per Section 21a-408-34(b), a Dispensary Facility will not dispense marijuana from, obtain marijuana from, or transfer marijuana to, a location outside of the state of Connecticut. Per Section 21a-408-34(c), a Dispensary Facility will not obtain, cultivate, deliver, transfer, transport, sell or dispense marijuana except:

- It may acquire marijuana from a producer.
- It may dispense and sell marijuana to a qualifying patient or primary caregiver who is registered with the DCP.

Per Section 21a-408-34(d), the Dispensary Facility will ensure that it does not provide marijuana samples or engage in marijuana compounding.

Security Leadership

In conjunction with the training provided by the Dispensary Facility Manager for all Dispensary Facility Employees, the Chief Security Officer will conduct security and emergency preparedness staff training by developing, scheduling and/or facilitating training for Dispensary Facility Employees in order to ensure that all Dispensary Facility Employees meet and exceed all building security requirements. The Chief Security Officer will provide oversight, and continual evaluation of the security plan of the company for the continuous improvement of proactive responsiveness to changing safety conditions. The Security/Surveillance Room will house video monitors for the live and recorded video feed collected from the video cameras located in, about and around the facility.

Inventory Control System and Auditing

The Dispensary Facility will utilize an Inventory Control System to track all marijuana that comes into the Dispensary's possession. This system will prevent any marijuana from being unaccounted for or misidentified.

System Selection

The Dispensary Facility will select an Inventory Control System in accordance with Sec. 21a-408-65. Since inventory management serves to deter theft and diversion of product, a strong auditing program at the Dispensary Facility will enable ongoing inventory controls and procedures for the conduct of inventory reviews and comprehensive inventories of marijuana. All inventories, procedures, and other documents related to inventory control will be maintained on the premises and made available immediately upon request for inspection and copying by the commissioner, their authorized representative, or others authorized to do so per Sec. 21a-408-65(d).

Inventory control systems also provide other solutions for the Dispensary Facility. Among other features, Dispensary Facility Management can analyze sales volume, plan when to order more or new products, connect qualifying patients with certain products, and more easily handle recalls and waste. Most inventory control systems integrate with point-of-sale (POS) software as well.

Marijuana can be sold in two forms after receipt from a producer per Sec. 21a-408-34(e):

- Only in the original sealed containers or packaging as delivered by the producer.
- Removed from the producer's child-resistant container or package and placed in a non-child-resistant, secure, and light-resistant container upon a written request from the qualifying patient or primary caregiver so long as all original labeling is maintained with the product.

Dispensary Facility Employees will use commercial barcode and/or RFID scanners to facilitate data entry, limit errors, and prevent subversion of marijuana products. Many inventory control programs are flexible with respect to data entry; still, the Dispensary Facility will choose an Inventory Control System that promotes ease of use along with versatile tools and stringent compliance. A commercial scale will be available as needed.

Auditing

To ensure that all marijuana is properly accounted for, the Dispensary Facility will regularly conduct inventory checks to make sure that all records of marijuana agree with the physical inventory.

Per Section 21a-408-65(a), the Dispensary Facility, prior to commencing business, will:

- Conduct an initial comprehensive inventory of all marijuana at the facility. If a facility commences business with no marijuana on hand, the Dispensary will record this fact as the initial inventory.

- Establish ongoing inventory controls and procedures for the conduct of inventory reviews and comprehensive inventories of marijuana, which will enable the facility to detect any diversion, theft or loss in a timely manner.

Per Section 21a-408-65(b), upon commencing business, the Dispensary Facility will conduct a weekly inventory of marijuana stock, which will include, at a minimum:

- The date of the inventory.
- A summary of the inventory findings.
- The name, signature and title of the individuals who conducted the inventory.
- The date of receipt of marijuana, the name and address of the producer from whom received, where applicable.
- The kind and quantity of marijuana received.

Records of marijuana sold, dispensed, or disposed of will show the following:

- Date of sale.
- Name of the Dispensary Facility.
- Name of qualifying patient or primary caregiver.
- Address of qualifying patient or primary caregiver
- Brand and quantity of marijuana sold.

The Dispensary Facility Management will conduct at least a weekly inventory of marijuana stock, which will include the following:

- Date of inventory.
- Summary of inventory findings.
- Name, signature, and title of individuals who conducted inventory.
- Date of receipt of marijuana.
- Name and address of the producer from whom the marijuana was received.
- Kind and quantity of marijuana received.

To prevent error build-up, smaller inventory audits will be performed daily. This aids to familiarize Dispensary Facility Employees with auditing procedures and not overwhelm just two Dispensary Facility Employees with inventory counting and reconciliation. Smaller daily audits will still be verified by two different Dispensary Facility Employees and subject to the same decisions.

In accordance with Sec. 21a-408-65(e), whenever any sample or record is removed by an authorized person, such person will tender a receipt in lieu thereof and the receipt will be kept for a period of at least three (3) years.

The Dispensary Facility Employee performing the inventory will directly input their findings into a device that interfaces with Inventory Control System. The inventory will be maintained in electronic format and will include the date of the inventory, a summary of the inventory findings, and the names, electronic signatures, and titles of the individuals who conducted the inventory.

In addition, the Dispensary Facility will conduct an annual comprehensive inventory, such inventory being taken on or before the anniversary of the initial inventory per Sec. 21a-408-65(c).

Reconciliations

Any changes made to the POS/inventory system must be reviewed and approved by a Dispensary or Dispensary Facility Management.

Reconciliations to inventory will be performed twice, by two separate Dispensary Facility Employees. Any problems or concerns with the reconciliation will be brought to the attention of Dispensary Facility Management and Chief Security Officer, who will immediately take all appropriate steps including, but not limited to, contacting the appropriate authorities if there is suspected criminal activity.

Waste Disposal Procedures and Storage

Because marijuana may need to be disposed of by the Dispensary Facility for a number of reasons, there must be protocols in place to prevent the diversion of marijuana identified for disposal. Marijuana may be undesired, excess, unauthorized, obsolete, adulterated, misbranded, deteriorated, or another characteristic unfit for sale.

No matter the reason, when marijuana is no longer suitable for dispensing, marijuana (now considered waste) will be moved in order to avoid contamination. The quarantined marijuana will then be removed from the Inventory Control System. All waste will first be securely stored while awaiting disposal by an authorized representative of the commissioner.

Furthermore, once the Dispensary Facility has identified all marijuana that is undesired, excess, unauthorized, obsolete, adulterated, misbranded or deteriorated, the Dispensary who has overseen the disposal of the marijuana will maintain and make available a separate record of every disposal in accordance with Sec. 21a-408-64(b) and Sec. 21a-408-70. Each record will indicate the following items:

- Date and time of disposal.
- Brand or product name to identify the marijuana.
- Quantity and/or weight of marijuana to be disposed.
- The manner of disposal.
- The volume and weight of the approved solid waste media used to render the marijuana unusable
- The unique identification codes associated with the marijuana scheduled for destruction.
- The reason(s) for and description of the disposal.
- Signatures of persons disposing of the marijuana, the authorized representative of the commissioner, and any other persons present during the disposal.

Per Section 21a-408-64(a), a Dispensary will dispose of undesired, excess, unauthorized, obsolete, adulterated, misbranded or deteriorated marijuana in the following manner:

- By surrender without compensation of such marijuana to the commissioner or the commissioner's authorized representative.

- By disposal in the presence of an authorized representative of the commissioner in such a manner as to render the marijuana non-recoverable.

Employee Policies

The Dispensary Facility will follow certain policies pertaining to all Dispensary Facility Employees to create a safe and secure environment for everyone who enters the facility.

General Employee Policies

In order to protect the premises for visitors, Dispensary Facility Employees, and qualifying patients and primary caregivers, the Dispensary Facility will operate with the following procedures:

- Dispensary Facility Employees will be directed to pay close attention to the access points to the Dispensary Facility. Any door that is intended to serve as a barrier between the restricted and limited access areas of the Dispensary Facility must remain closed and locked at all times, except for the moment when an authorized individual is walking through it.
- The Dispensary Facility Employees will only have access to the portions of the Dispensary Facility that relate to their function at work. For instance, a Dispensary Facility Employee only working in the limited access area will not have access to the Security/Surveillance room.
- All Dispensary Facility Employees will have training in accordance with the personnel policies and procedures, and such training will be conducted by experts in the respective areas.
- All Dispensary Facility Employees will receive loss prevention and safety training and will have to attend and pass an online armed robbery awareness course, conducted by a licensed high-risk security consultant. All security training certifications received will be stored in the employee's personnel file.
- Each registered Dispensary Facility Employee must wear a color-coded employee identification badge at all times while at the Dispensary Facility.
- At least two registered Dispensary Facility Employees will be on-site at all times during regular business hours to ensure that the Dispensary Facility has at least two persons present from opening to closing.

Per Section 21a-408-34(h), a Dispensary Facility will not permit any person to enter the Dispensary Department unless:

- Such person is licensed or registered by the department pursuant to 21a-408-1 to 21a-408-70, inclusive, of the Regulations of Connecticut State Agencies.
- Such person's responsibilities necessitate access to the Dispensary Department and then for only as long as necessary to perform the person's job duties.
- Such person has a qualifying patient or primary caregiver registration certificate, in which case such person will not be permitted behind the service counter or in other areas where marijuana is stored.

Per Section 21a-408-34(i), all Dispensary Facility Employees will, at all times while at the Dispensary Facility, have their current Dispensary license, Dispensary Technician registration or

Dispensary Facility Employee registration available for inspection by the commissioner or the commissioner's authorized representative. This will prevent covert attempts to infiltrate the Dispensary Facility and steal or divert marijuana.

Per Section 21a-408-34(j), while inside the Dispensary Facility, all Dispensary Facility Employees will wear name tags or similar forms of identification that clearly identify them to the public, including their position at the Dispensary Facility. In conjunction with video surveillance, this will assist identification of any individuals involved in suspicious or prohibited activity.

Searching and Screening

All packages or handheld items are subject to search before entry or exit from the property. Such searches will be authorized by the Dispensary Facility Manager or Chief Security Officer, and based upon a valid security concern. U.S. mail (letters) are excluded from search if properly marked, sealed or otherwise identified in documentation. The Dispensary Facility Manager and Chief Security Officer are responsible for establishing package controls to minimize the loss of property and to mitigate internal theft. Product or property will never be removed from the Dispensary facility without proper documentation or authorization. All Dispensary facility outgoing boxes, containers, will be inspected. Boxes exiting the Dispensary Facility will be inspected prior to employee packaging, sealing, and mailing through a commercial carrier. Authorized Dispensary Facility Employees will note the shipment, recipient, inspection, and date of mailing within a log book.

The Chief Security Officer, Security Officer or other authorized Dispensary Facility Employee will inspect all outgoing trash bags carried out of the Dispensary facility, which are to be deposited in the outside locked trash receptacle. Post trash inspection, the bag will be secured using a plastic tie affixed by the Chief Security Officer, Security Officer or other authorized Dispensary Facility Employee. An authorized Dispensary Facility Employee will be escorted by another authorized Dispensary Facility Employee to the outside trash receptacle, lid unlocked, and trash deposited. Post depositing the trash, the receptacle will be locked. Prior to trash pickup the trash receptacle will be unlocked, locks removed, and the receptacle monitored via the security system. Once the trash has been emptied by the local trash pickup service, the lock will be reaffixed to the container.

Security personnel will perform periodic spot checks of trucks or other conveyances for unauthorized contraband or company property either upon entering, traveling within the property or before exiting to ensure theft or diversion does not occur.

Hiring Policies

The Dispensary Facility will follow certain policies on hiring to establish a safe and compliant work environment.

The Dispensary Facility will conduct a criminal history background check and conduct comprehensive interviews on any prospective Dispensary Facility Employee prior to hiring that individual. The Dispensary Facility will keep records of the results of the criminal history background checks. The Dispensary Facility will record confirmation of criminal history

background checks and make the confirmation of criminal history background checks available for inspection upon request by the DCP or authorized persons. Dispensary Facility Employee records are subject to inspection or examination by the DCP, through its investigators, agents, auditors, or the state police to determine compliance with the act or these rules.

Each Dispensary Facility Employee will sign a confidentiality agreement, the breach of which will be cause for immediate termination; and such confidentiality agreement, among other things, will prohibit a Dispensary Facility Employee from sharing their access proximity security card and/or pin code. The Dispensary Facility will make available to the DCP, upon request, a current list of authorized Dispensary Facility Employees and service employees who have access to the surveillance room.

Disciplinary Actions

The Dispensary Facility strives to create a “Culture of Honesty” and has an open communication policy. It is the responsibility of all Dispensary Facility Employees to report dishonest behavior or theft-related issues to the owner or manager. The Dispensary Facility may immediately dismiss any Dispensary Facility Employee who has:

- Attempted misappropriation of marijuana or cash.
- Violated any safety standard and/or any other rule, policy or procedure of the Dispensary Facility.
- Removed from the Dispensary Facility premises or concealed monies, merchandise, or property belonging to the Dispensary Facility, other Dispensary Facility Employee or other persons.
- Failed to report the dishonesty of another when the Dispensary Facility employee has reasonable knowledge of such dishonesty.
- Discounted marijuana without authorization.
- Failed to ring a sale, or properly account for or control funds.
- Violated a criminal statute.
- Made a false statement to Dispensary Facility Management or engaged in a fraudulent act.
- Entered, or causing to be entered, information which the Dispensary Facility employee knows to be false, or reasonably should have known to be false, on any Dispensary Facility document, report, form or record.
- Accepted gratuities from vendors, contractors, visitors or other Dispensary Facility employees.
- Has been insubordinate, refused to follow work-related directions from a Dispensary Facility manager or supervisor.
- Engaged in misconduct toward a visitor, contractor, vendors, manager or coworker including but not limited to:
 - threatening
 - intimidation
 - coercing
 - fighting
 - using foul or abusive language
 - engaging in any action that could result in injury or damage to persons or property

- speaking negatively about a coworker to a visitor, vendor or contractor
- Violated the Alcohol and Drug Abuse Policy.
- Transacted personal business during working hours.
- Used company property or assets for personal reasons without prior approval.
- Destructed, damaged or misused company property or assets.
- Engaged in disorderly or illegal conduct on the premises.
- Harassed another person, made racist or sexually offensive remarks, physically touched or made inappropriate suggestions to any individual in the course of employment or while on company premises
- Acted contrary to the best interests of the company such as diverted sales or divulged proprietary information.
- Neglected or demonstrated incompetence in the performance of job responsibilities.
- Violated any Dispensary Facility policy or procedure.
- Failed to follow the Dispensary Facility policy which resulting in the loss of monies, merchandise, or other Company assets.

Employee Suspensions and Terminations

- The Dispensary Facility will ensure all passwords, key locks and combinations of a terminated Dispensary Facility Employee are changed upon termination.
- The implementation of additional security measures, such as consultation with a threat assessment professional, may be used when a Dispensary Facility Employee of concern is terminated.
- A terminated Dispensary Facility employee will be searched to ensure all Dispensary Facility property, data and equipment, including marijuana and cash, are recovered from the terminated employee prior to their departure from the facility.
- A terminated or suspended Dispensary Facility Employee will surrender their company access card immediately.
- If the terminated Dispensary Facility Employee refuses to return company property will be subject to legal action.

Employee Training and Management

How companies handle significant events can have a long-term effect on their business operations. It is imperative that Dispensary Facility employees prepare for unfavorable events in order to avoid panic, handle a situation optimally, and resume work promptly. By implementing training for stressful events, Dispensary Facility Employees can act dutifully and more confidently should the scenario occur.

Armed Robbery Training

Armed robberies can be traumatic and chaotic events. Therefore, the Dispensary Facility will emphasize Dispensary Facility Employee training on this topic.

All Dispensary Facility Employees will receive training concerning procedures that will be implemented in the event of an attempted robbery. The primary objectives of these procedures

will be the protection of human life. Dispensary Facility Management will be primarily responsible for implementing these procedures and for directing others during an event.

The Dispensary Facility will be using an “Armed Robbery Training Program” which educates and trains Dispensary Facility Employees in effectively dealing with an armed robbery if one should occur. The Dispensary Facility feels that educating Dispensary Facility employees on best practices during an armed robbery will minimize the risk of injury during a robbery. Dispensary Facility Employees will acquire the knowledge, procedures and confidence to respond to a robbery safely and effectively. In addition, the program is designed to assist the Dispensary Facility in getting back to normal business operations as quickly as possible in the event of an armed robbery.

Post-Robbery Instruction Kit

Regardless of the training Dispensary Facility Employees receive, when a robbery occurs, it is traumatic and chaotic. Having an easy to follow post-robbery protocol after an incident will greatly reduce this stress and decrease the time to resuming business. The Dispensary Facility will have a post-robbery instruction incident kit which will be stored in the Security/Surveillance Room. The kit will include all of the essential documents necessary to properly manage a robbery after it occurs:

- Detailed “After an Armed Robbery” instructional document.
- Robbery Description/Weapon Identification Forms.
- Reward for information signs.

Other Security Training

Successful diversion prevention techniques result from a well-informed, trained and educated staff and a comprehensive security training/education program. Prior to starting employment, Dispensary Facility Employees will receive training on the proper use of security measures and controls that have been adopted for the prevention of diversion, theft or loss of marijuana. Sec. 21a-408-45(a)(1).

The Dispensary Facility does not consider completion of mandatory diversion prevention training a fulfillment of this requirement. Examinations with pass/fail scores are also part of the training. The Dispensary Facility provides instruction that leads to effective education of personnel in subjects tailored to suit the nature of the individual’s responsibilities and collateral within the Dispensary Facility. It is the responsibility of all Dispensary Facility Employees to actively work towards preventing diversion, while employed by the Dispensary Facility.

Additional Dispensary Facility Employee security and safety training includes, but is not limited to, the following:

- Reviewing Federal and Connecticut marijuana laws and regulations.
- Theft, Loss, and Diversion Awareness
 - Detection and preventing diversion of marijuana
 - External marijuana theft awareness
 - Internal marijuana theft awareness
 - Cash theft awareness

- Standard Response Safety Protocols.
 - Shelter protocol
 - Evacuation protocol
 - Lockout protocol
 - Lockdown protocol
 - Medical emergencies
 - Other criminal incidents

Reporting Events

Due to the nature of the business, there is the potential for events to occur that need to be reported to Dispensary Facility Management and authorities. The Dispensary Facility’s policy will ensure that these events are always reported by whoever witnesses them.

Dispensary Facility Employees will be trained to report security personnel, or upper-management, if they have reasonable cause to suspect loss or theft of marijuana and/or cash. Sec. 21a-408-45(a)(1). The Dispensary Facility will investigate each report of loss or theft. This investigation will be conducted by the Dispensary Facility Manager and the Chief Security Officer and shall include witness interviews and the review of all physical evidence including surveillance footage of the incident. An incident report and applicable documentation, will be stored in the Dispensary Facility database per Sec. 21a-408-49(a)(1)(2)(3) and easily queried for record searching and archiving for at least three years per Sec. 21a-408-70(a).

Investigations

It is the responsibility of every Dispensary Facility Employee who witnesses or suspects criminal activity at the Dispensary Facility to report it immediately to the Dispensaries, Dispensary Facility Management or the authorities. As part of the Dispensary Facility’s whistleblower policy, Dispensary Facility Management will have an open-door policy, and Dispensary Facility employees will be able to make such reports confidentially without fear of reciprocity or retaliation. All Dispensary Facility employees and owners will receive training on the Dispensary Facility’s whistleblower policy to ensure that appropriate policies are followed and employee rights are protected. The Dispensary Facility’s whistleblower policy will:

- Protect any person whose disclosure of corruption is supported by a reasonable belief that it is true.
- Protect those who challenge national or international illegality, as well as abuse of authority, mismanagement, gross waste, or a substantial health or safety threat.
- Protect those who refuse to violate the law.
- Protect not only staff, but contractors and their employees, private citizens, or any entity exercising free speech rights to challenge abuses of power.
- Outlaw all forms of harassment, including threatened or recommended harassment.
- Establish confidentiality protection, including the right for prior review by whistleblowers of releases that otherwise might inadvertently disclose their identities, and accountability by designating confidentiality breaches as actionable misconduct.
- Commit to an independent Alternative Disputes Resolution in which Dispensary Facility employees are partners in establishing the rules for resolution of their cases.
- Provide interim relief for reprisal victims while the case is pending.

Per Sec. 21a-408-63(a) the Dispensary will notify the DCP Drug Control Division and all appropriate law enforcement authorities immediately upon becoming aware of the following:

- Any discrepancy identified during inventory.
- Any suspicious act involving the sale, distribution, manufacturing, or production of marijuana by any person on premises.
- Unauthorized destruction of marijuana products by any person.
- Any loss or unauthorized alteration of company records or records related to qualifying patients.
- Any diversion, theft, or loss.

Per Sec. 21a-408-63(b) the Dispensary will provide a written notice of the event to the DCP no later than 24 hours after discovery of the event by way of a signed statement. This signed statement will detail the following:

- The circumstances of the event.
- An accurate inventory of the quantity and brand names of the marijuana products diverted, stolen, lost, destroyed, or damaged.
- Confirmation that local law enforcement authorities were notified.

Per Sec. 21a-408-63(c) the Dispensary will notify the Drug Control Division and the DCP no later than the next business day, followed by written notification no later than 10 business days, of any of the following:

- An alarm activation or another event that requires response by public safety personnel.
- A breach of security.
- The failure of the security alarm system due to a loss of electrical support or mechanical malfunction that is expected to last more than 8 hours.
- Any corrective measures, including and not limited to changes in physical security measures, policies, and personnel, that have been or are being taken.

In accordance with Sec. 21a-408-63(d), the Dispensary Facility will maintain and make available all documentation related to an occurrence that is reportable and will cooperate with any law enforcement investigations or directives from the DCP.

Recordkeeping

Accurate recordkeeping policies will protect the Dispensary Facility against any diversion or theft by accounting for all marijuana and marijuana sales. Through the use of these records, Dispensary Facility management and the DCP can readily know what marijuana exists in the Dispensary Facility, where it is, where it came from, and to whom it was sold.

Dispensary Facility Records

The Dispensary Facility Management will keep clear and accurate records of all relevant information pertaining to marijuana storage, receiving, and sales. Per Section 21a-408-69(a), the Dispensary Facility Management will maintain a complete set of all records necessary to fully show the business transactions related to marijuana for a period of the current tax year and the three immediately prior tax years, all of which will be made available in accordance with section

21a-408-70 of the Regulations of Connecticut State Agencies. These records will include but not be limited to all transaction records, personnel records, policies, procedures, contracts, audits, reportable events, incident reports and all other business records.

Access to Records

All Dispensary Facility records will be maintained in an electronic format, encrypted and backed up off-site. All records shall be kept in a locked, restricted access area when not in use. The Dispensary Facility will at all times keep clear and accurate records that will be accessible to the DCP or any other regulatory or legal authority who is legally allowed to have access to these records. The Dispensary Facility shall set levels of restriction for certain records. For example, only certain Dispensary Facility Employees shall have access to records involving personnel and incidents/investigations at the facility. Levels of access shall be maintained by using information technology platforms to restrict certain Dispensary Facility employees from access to all records. If certain sensitive or confidential records are in physical form, the Dispensary Facility Management shall take steps to ensure that only certain Dispensary Facility Employees have access to those records by storing them in a safe off-site.

Per Section 21a-408-70(a), the Dispensary Facility Manager, or other authorized Dispensary Facility Employee, will prepare, obtain or keep records, logs, reports or other Dispensary Facility documents of the Dispensary Facility, and will maintain such documents in an auditable format for no less than three (3) years. Upon request, Dispensary Facility Employees will make such documents immediately available for inspection and copying by the commissioner, the commissioner's authorized representative or others authorized by the Act or Sections 21a-408-1 to 21a-408-69, inclusive, of the Regulations of Connecticut State Agencies, to review the documents. In complying with this section, no Dispensary Facility Employee will use a foreign language, codes or symbols to designate marijuana types or persons in the keeping of any required document. The Dispensary Facility will furnish any information, including, an audit of the business, to the commissioner upon request and at the Dispensary Facility's expense per Section 21a-408-69(b),

Per Section 21a-408-70(b), Dispensary Facility Management is aware that for purposes of the supervision and enforcement of the medical marijuana program, the commissioner or the commissioner's authorized representative, is authorized:

- To enter, at reasonable times, any place, including a vehicle, in which marijuana is held, dispensed, sold, produced, delivered, transported, manufactured or otherwise disposed of.
- To inspect within reasonable limits and in a reasonable manner, such place and all pertinent equipment, finished and unfinished material, containers and labeling, and all things therein including records, files, financial data, sales data, shipping data, pricing data, employee data, research, papers, processes, controls and facilities.

- To inventory any stock of marijuana therein and obtain samples of any marijuana or marijuana product, any labels or containers for marijuana, paraphernalia, and of any finished and unfinished material.

Per Section 21a-408-39(c), if the Dispensary Facility closes temporarily or permanently, the Dispensary Facility will, in the interest of public health, safety and convenience, make its complete dispensing records immediately available to a nearby Dispensary Facility and post a notice of this availability on the window or door of the closed Dispensary Facility. The Dispensary Facility will simultaneously provide such notice to the commissioner.

Labeling

To ensure proper labeling of medical marijuana, the Dispensary Facility will maintain procedures to comply with state law. The Dispensary, or a Dispensary Technician under the direct supervision of the Dispensary, shall completely and properly label all marijuana products dispensed with all required information in conjunction with the inventory control system and prescription monitoring program as follows per Sec. 21a-408-40:

- The serial number, as assigned by the Dispensary.
- The date of dispensing the marijuana.
- The quantity of marijuana dispensed.
- The name and registration certificate number of the qualifying patient and, where applicable, the primary caregiver.
- The name of the certifying physician.
- Such directions for use as may be included in the physician's written certification or otherwise provided by the physician.
- Name of the Dispensary.
- Name and address of the Dispensary Facility.
- Any cautionary statement as may be required by Connecticut state statute or regulation.
- A prominently printed expiration date based on the producer's recommended conditions of use and storage. that can be read and understood by the ordinary individual.

Per Section 21a-408-39(a), the Dispensary will assign and record a sequential serial number to each marijuana product dispensed to a qualifying patient and will keep all dispensing records in numerical order in a suitable file, electronic file or ledger. The records will indicate:

1. The date of dispensing.
2. The name and address of the certifying physician.
3. The name and address of the qualifying patient, or primary caregiver if applicable.
4. The initials of the Dispensary who dispensed the marijuana.
5. Whether a full or partial one-month supply of marijuana was dispensed.

Per Section 21a-408-39(b), the Dispensary Facility will maintain records created under this section and will make such records available in accordance with section 21a-408-70 of the Regulations of Connecticut State Agencies.

Dispensary Facility Diversion Prevention

Dispensing to Qualifying Patients

It is in the best interest of the Dispensary Facility and the Dispensaries to prevent marijuana diversion and ensure qualifying patients and primary caregivers do not abuse access to marijuana.

Dispensaries will utilize qualifying patient records, inventory control systems, and training from the Dispensary Facility to detect and deter diversion. Per Section 21a-408-38(a), a Dispensary, in good faith, may sell and dispense marijuana to any qualifying patient or primary caregiver that is registered with the department. Except as otherwise stated by the Regulations of Connecticut State Agencies, the Dispensary dispensing the marijuana will include the date of dispensing and the Dispensary's signature or initials on the Dispensary Facility's dispensing record log.

Per Section 21a-408-38(f), a Dispensary, or Dispensary Technician, will require the presentation of a registration certificate together with another valid photographic identification issued to a qualifying patient or primary caregiver, prior to selling marijuana to such qualifying patient or primary caregiver. Per Section 21a-408-38(e), a Dispensary may dispense a portion of a qualifying patient's one-month supply of marijuana. The Dispensary may dispense the remaining portion of the one-month supply of marijuana at any time except that no qualifying patient or primary caregiver will receive more than a one-month supply of marijuana in a one-month period.

Per Section 21a-408-38(c), a Dispensary will review a qualifying patient's controlled substance history report within the prescription monitoring program before dispensing any marijuana to the qualifying patient or the qualifying patient's primary caregiver. Per Section 21a-408-38(d), a Dispensary will exercise professional judgment to determine whether to dispense marijuana to a qualifying patient or primary caregiver if the Dispensary suspects that dispensing marijuana to the qualifying patient or primary caregiver may have negative health or safety consequences for the qualifying patient or the public.

Per Section 21a-408-38(g), a Dispensary will document a qualifying patient's self-assessment of the effects of marijuana in treating the qualifying patient's debilitating medical condition or the symptoms thereof. A Dispensary Facility will maintain such documentation electronically for at least three (3) years following the date the qualifying patient ceases to designate the Dispensary Facility and such documentation will be made available in accordance with Section 21a-408-70.

If a Dispensary, the Chief Security Officer, or another Dispensary Facility Employee believes diversion by a qualifying patient or primary caregiver is occurring, an investigation will open as previously described herein and in accordance with Sec. 21a-408-63.

Emergency Evacuation and Response Plan

It is a reality that emergency situations can arise at any time. The Dispensary Facility's evacuation and response procedures will protect Dispensary Facility Employees, qualifying

patients, primary caregivers should an emergency occur. These response plans will prepare Dispensary Facility Employees to safely handle the emergencies.

Preparations

The Dispensary Facility will anticipate emergency situations and prepare accordingly for them. The Dispensary Facility Manager and the Chief Security Officer, will conduct security and emergency preparedness staff training by developing, scheduling and/or facilitating training for Dispensary Facility Employees in order to ensure that all Dispensary Facility employees are trained in procedures and instructions for responding to an emergency per Sec 21a-408-45(a)(2).

Procedures and instructions for responding to an emergency will include:

- Accident prevention training.
- How to respond to an emergency.
- Emergency service provider location.
- Emergency service contact information.
- Emergency first aid kit locations.
- Emergency exits and panic button locations.

The Chief Security Officer will provide oversight, and continual evaluation of the Dispensary Facility's security plan for the continuous betterment of proactive responsiveness to changing safety conditions. In addition, the Security/Surveillance Room will house all sensitive information such as keys, codes, vehicle records and reports in a secured, safe, and locked closet.

The Dispensary Facility will prepare for, protect against, and handle any crises that affect the security or operation of the Dispensary Facility in the event of a fire, flood, or other natural disaster, or other situations of local, state, or national emergency. Emergency preparedness drills will be conducted every year. In case of an emergency, it will be responsibility of the Dispensary Facility Management to evaluate an emergency situation, see that appropriate action is taken, determine whether outside support is needed and summon support, if necessary. Dispensary Facility Management will also ensure that they have valid phone number for all employees, i.e.: cell phones or home numbers, in case they need to contact them.

The Dispensary Facility will have emergency supplies ready in case of an emergency. These supplies will be stored in the security room. The following items will be available in the security room:

- Battery-Operated Flashlight.
- Battery-Operated Radio.
- Batteries Sized to fit the Flashlight and Radio.
- First Aid Kit.
- Evacuation Diagram.
- Another copy of this diagram will be posted in the break room.
- Working Fire Extinguisher.
- Emergency Whistle.

Emergency Responses

The Dispensary Facility will use a standard response safety protocol system to enable a rapid response during unforeseen events. By utilizing the standard response safety protocol system, the Dispensary Facility will allow for a more predictable and uniform series of actions as an event unfolds. The Dispensary Facility will standardize the protocol vocabulary so all Dispensary Facility Employees will understand the response and status of the event, providing continuity of expectations and actions. The standard response safety protocols will be understood and rehearsed by all Dispensary Facility employees and coordinated with local emergency responders.

The first step with any emergency response is to quickly and accurately communicate the situation with local law enforcement/including EMS services when necessary. The next step is to follow a simple, pre-planned and rehearsed command to initiate an action amongst all Dispensary Facility employees. These actions place the safety of persons first while also making it a priority to safely secure marijuana and funds so that no diversion occurs as a result of these emergencies.

Severe Weather Shelter Protocol

During severe weather events such as blizzards, a shelter protocol will be initiated for group and self-protection. The shelter protocol may be necessary to protect Dispensary Facility employees and qualifying patients and primary caregivers during severe weather events where seeking hardened protection is prudent. Upon the initiation of shelter protocol, all Dispensary Facility employees will cease all work activity and assist qualifying patients and primary caregivers to pre-determined hardened shelter and await further instructions. All Dispensary Facility employees will remain at the pre-determined rallying site until all Dispensary Facility employees have been accounted for.

Emergency Evacuation Protocol

In case of fire, industrial accident, bomb threat or other emergency, an evacuation protocol will be used to move Dispensary Facility employees from the Dispensary Facility to an external rallying point. Each area of the Dispensary Facility will have pre-determined evacuation routes clearly posted in all work areas, and Dispensary Facility employees will be briefed on these routes and periodically rehearse them. Upon the initiation of the evacuation protocol, all Dispensary Facility employees will immediately cease their work activity and assist qualifying patients and primary caregivers to the pre-determined evacuation rally site. Dispensary Facility Employees assigned a safety function will be the last to exit the building whenever possible. One Dispensary Facility employee will be assigned to take the First Aid Kit as they leave the building. A designated employee will notify the Police and Fire Department by calling 911. All Dispensary Facility Employees will remain at the pre-determined rallying site until all Dispensary Facility employees have been accounted for.

Additional steps to be taken in the event of a fire include:

- If a fire cannot be easily and safely extinguished by the Dispensary Facility Employees discovering it, immediately notify all persons present of the fire.
- Direct all persons present to evacuate the building using the nearest safe exit.

- If possible, turn off electrical equipment and close doors against the fire.

Additional steps to be taken in the event of a bomb threat include:

- Reinforce that bomb threats must be taken seriously.
- A Dispensary Facility Employee receiving a bomb threat will notify their supervisor and/or a member of the Dispensary Facility Management immediately.

Active Threat Nearby: Lockout Protocol

If an active threat is witnessed or reported within reasonable proximity of the Dispensary Facility, a lockout protocol will be initiated to safeguard everyone within. The lockout protocol is designed to prevent entry into the Dispensary Facility by unknown, suspicious or dangerous individuals, and to maintain accountability and security of all Dispensary Facility Employees. All exterior doors and windows will be locked and secured. No one will be allowed into or out of the Dispensary Facility until the situation that caused the lockout is resolved.

Active Threat Inside: Lockdown Protocol

If an active threat is identified, a lockdown protocol will be initiated to safeguard everyone. The lockdown protocol is used to secure individual rooms and to keep Dispensary Facility employees safely in place.

Upon the initiation of a lockdown, all Dispensary Facility Employees will assist visitors to rapidly move to predetermined lockable and secured sites. Only law enforcement is trained to react and confront an active shooter situation. All Dispensary Facility Employees and authorized visitors will remain secured within the locked sites until personally contacted by law enforcement or Dispensary Facility Management, indicating all is clear and safe. At the conclusion of a lockdown protocol, a full accountability of Dispensary Facility Employees and authorized visitors will be determined.

Power Outage

If there is a loss of power, designated Dispensary Facility Employees with flashlights will direct all Dispensary Facility employees and authorized visitors to a designated area until power resumes. All Dispensary Facility Employees will remain in the designated area until all Dispensary Facility employees are accounted for. This designated area will not be in close proximity to marijuana. Authorized visitors may be permitted to leave.

Interior Signage

The Dispensary Facility will use signage as a deterrent against theft and diversion.

In accordance with Sec. 21a-408-51(a)(9), a sign will be posted at all entry ways into any area of the Dispensary Facility containing marijuana, including rooms with a safe or the Secure Storage Vault, which sign will be a minimum of twelve inches in height and twelve inches in width which will state in lettering no smaller than one-half inch in height:

**“DO NOT ENTER - LIMITED ACCESS AREA – ACCESS LIMITED TO
AUTHORIZED EMPLOYEES ONLY.”**

NO INGRESE–ÁREA DE ACCESO LIMITADO–ACCESO LIMITADO SÓLO A LOS EMPLEADOS AUTORIZADOS.”

The Dispensary Facility will post signs informing individuals of the surveillance system by the Main Entry and in conspicuous locations inside the Dispensary Facility. The signs will be a minimum of 12 inches in height and 12 inches in width in lettering no smaller than ½ inch in height:

**“NOTICE: VIDEO SURVEILLANCE IS IN USE ON THESE PREMISES.
AVISO: LA VIGILANCIA VÍDEO ESTÁ EN USO EN ESTOS LOCALES.”**

In the Waiting Room, the Dispensary Facility will post signs informing individuals that all safes have a time delay. Since time delays are effective at reducing robbery losses, this notice is intended to deter criminals from attempting an armed robbery.

Dispensing Reporting and Errors

The Dispensary Facility recognizes that protocol and procedures need to be in place to handle errors in dispensing and reporting. Identifying and eliminating errors is crucial to the success of its security and anti-diversion plans. Should a qualifying patient have a problem with the marijuana that was purchased, the qualifying patient needs to be able to immediately contact the Dispensary Facility or regulatory authorities. The Dispensary Facility’s signs, labeling, and other protocols will inform qualifying patients how to easily contact relevant entities to correct any problem with their purchase.

Dispensing Error Reporting and Quality Assurance Program

In the event that a qualifying patient has a problem with their marijuana purchase, the signs in the Dispensary Facility and the information on the purchase receipt will afford the qualifying patient with the information needed to rectify the situation.

In accordance with Sec. 21a-408-47, the Dispensary Facility will post a sign concerning the reporting of dispensing errors in a conspicuous location visible to qualifying patients and primary caregivers. The sign will follow these requirements: will measure a minimum of eight inches in height and ten inches in width and the lettering will be in a size and style that allows such sign to be read without difficulty by consumers standing at the dispensary department, will state: “If you have a concern that an error may have occurred in the dispensing of your marijuana, you may contact the Department of Consumer Protection, Drug Control Division, by calling (Department of Consumer Protection telephone number authorized pursuant to section 21a-2 of the Connecticut General Statutes).”

In addition, the Dispensary Facility will include the following printed statement on the receipt or in the bag or other similar packaging in which marijuana is contained: “If you have a concern that an error may have occurred in the dispensing of your marijuana, you may contact the Department of Consumer Protection, Drug Control Division, by calling (Department of Consumer Protection telephone number authorized pursuant to section 21a-2 of the Connecticut General Statutes).” In accordance with Sec. 21a-408-47 of the Connecticut Security Regulations,

the Dispensary Facility will print such statement in a size and style that allows it to be read without difficulty by qualifying patients.

The Dispensary Facility Manager will develop a quality assurance program that describes, in writing, policies and procedures to detect, identify and prevent dispensing errors. Also, a written copy will be provided to the commissioner of a quality assurance program that will be distributed to all Dispensary Facility Employees and it will be made readily available on the premises of the Dispensary Facility. The policies and procedures will include:

- Directions for communicating the details of a dispensing error to the physician who certified a qualifying patient and to the qualifying patient, the patient's primary caregiver or appropriate family member if the qualifying patient is deceased or is unable to fully comprehend the communication.
- Such communication will describe methods of correcting the dispensing error or reducing the negative impact of the error on the qualifying patient.
- A process to document and assess dispensing errors to determine the cause of the error and an appropriate response.

A Dispensary Facility Manager will utilize the findings of its quality assurance program to develop dispensary systems and workflow processes designed to prevent dispensing errors. Indeed, the Dispensary Facility Manager will inform dispensary facility employees of changes to dispensary facility policy, procedure, systems, or processes made as a result of recommendations generated by the quality assurance program.

Review of Dispensing Errors

Should a dispensing error occur, the Dispensary Facility's protocols will efficiently and effectively handle the situation.

In accordance with Sec. 21a-408-48 of the Connecticut Security Regulations, it is the responsibility of the Dispensary Facility Manager to notify all Dispensary Facility Employees of any errors. The Dispensary Facility Manager will guarantee that a Dispensary performs a quality assurance review for each dispensing error as soon as is reasonably possible, but no later than two business days from the date the dispensing error is discovered. Moreover, the Dispensary Facility Manager will create a record of every quality assurance review and will maintain these records in an orderly manner and file by date.

This record will contain at least the following:

- The date or dates of the quality assurance review.
- The names and titles of the persons performing the review.
- The pertinent data and other information relating to the dispensing error reviewed.
- Documentation of contact with the qualifying patient, primary caregiver where applicable, and the physician who certified the qualifying patient as required by the quality assurance program implemented
- The findings and determinations generated by the quality assurance review.
- Recommended changes to dispensary facility policy, procedure, systems, or processes, if any.

Overall, a copy of the Dispensary Facility's quality assurance program and records of all reported dispensing errors and quality assurance reviews and documents will be made available in accordance with Section 21a-408-70.

Dispensary Reporting into the Prescription Monitoring Program

In accordance with Sec. 21a-408-50, the Dispensary will report electronically to the Drug Control Division of the department, at least once per day. The information can be found in the most recent edition of the Standard for Prescription Monitoring Programs established by the American Society for Automation in Pharmacy at www.asapnet.org.

The Dispensary will transmit to the department, in a format approved by the department, including, but not limited to, the following:

- Drug Enforcement Administration Pharmacy number, which will be populated by a number provided by the department.
- Birth date.
- Sex code.
- Date order filled, which will be the date marijuana is dispensed.
- Order number, which will be the serial number assigned to each marijuana product dispensed to a qualifying patient.
- New-refill code.
- Quantity.
- Days' supply.
- National Drug Code number, which will be provided by the department.
- Drug Enforcement Administration Prescriber identification number.
- Date order written, which will be the date the written certification was issued.
- Number of refills authorized.
- Order origin code, which will be provided by the department
- Qualifying patient last name.
- Qualifying patient first name.
- Qualifying patient street address.
- State.
- Payment code for either cash or third-party provider.
- Drug name, which will be the brand name of the marijuana product.

The Dispensary will transmit the information in such a manner, as to insure the confidentiality of the information in compliance with all federal and Connecticut state statutes and regulations, including the federal Health Insurance Portability and Accountability Act of 1996, Public Law 104-191.

EXTERIOR SECURITY

It is of the utmost importance that the premises of the Dispensary Facility are always maintained in a safe and secure manner. Commercial grade signs, alarms, security personnel, and other measures will be used to create a secure facility for Dispensary Facility employees and patrons.

The Dispensary Facility will proactively limit concealment outside the premises and will install safety measures that cannot be manipulated. All potential problems in exterior security will be anticipated and guarded against so that these problems cannot lead to breaches in security.

Overview of Perimeter Security

The Dispensary Facility will design the Dispensary Facility with security in mind. The Dispensary Facility will always maintain and clean the grounds around the perimeter to ensure good standing in the community. The perimeter will be designed and maintained with the goal to discourage theft and diversion of marijuana. The Dispensary Facility will ensure that all marijuana will not be visible or accessible from the outside of the premises at all times.

The video surveillance system will encompass the entire perimeter and parking lot and record all activity 24/7. The Dispensary Facility's video security system will include infrared-sensitive analytic cameras that can detect people entering the Dispensary Facility in low- to no-light situations. The outside perimeter of the Dispensary Facility will be well-lit to accommodate video surveillance. The premises will also be monitored by the intrusion detection alarm system. The combination of motion detectors and glass break detectors will ensure the perimeter always has alarms in accordance with Sec. 21a-408-62(a)(1). Video analytics services will be utilized in the event of an alarm activation to sync the event with persons and activity.

Lighting

Statistics show that crimes are less likely to occur in well-lit areas because a well-lighted property is an excellent deterrent against criminals. Security lighting is one of the most practical and effective ways to prevent crime in or around commercial facilities. Thus, the Dispensary Facility will keep the outside perimeter of the Dispensary Facility premises well-lit per 21a-408-62(e).

The main objectives of the security lighting system at the Dispensary Facility are to illuminate dark areas and detect and recognize movement in the protected area. The best vision with outdoor lighting is obtained from downward directed and shielded security lighting that is constantly on, supplemented with instant-on lighting triggered by motion detectors. All entrances and windows will be fully illuminated during the hours of darkness to a minimum of 500 lux. Additionally, 1,000 lux motion activated lighting will illuminate exterior doors and windows. Lux is the measurement unit of illumination and luminous emittance, measuring luminous flux per unit area.

All lighting used to light the premises will be deflected away from adjacent properties and used to illuminate the Dispensary Facility perimeter. Lighting will cover all entrances and exits, all possible points of intrusion, sidewalks and adjoining sidewalks, facades, parking lots, immediate surrounding areas, and exterior walls of the Dispensary Facility. Cones of illumination will be directed downwards to direct beams of light in an overlapping fashion in case of bulb failure. Parking lot lighting will fully illuminate the parking lot at night allowing for clear and accurate video recording as well as employee safety when going to their vehicles. Automatically controlled lighting will be checked and inspected regularly for proper operation prior to darkness.

The lighting system will have a dependable auxiliary source of power that is independent of the power system. Parallel circuit wiring will be used to prevent system failure in the event a bulb fails in any one fixture. Where practical, wiring will be placed underground in tamper resistant conduit. If above ground, height will reduce the possibility of tampering.

Adequate emergency lighting will be provided for indoor evacuation routes and will go into operation automatically when needed. The lighting system will be designed, and exact locations recorded, so that repairs can be made more rapidly in an emergency. Switches and controls will be properly located, waterproof and tamper resistant, and centrally located. The lighting system will be regularly inspected, and any failures will be repaired within 24 hours.

Windows, Bollards, Foliage

Windows will be secured against entrance or breakage and the Dispensary Facility will install glass break alarm detectors for all windows. Lighting near windows will be supplemented with motion-activated lighting.

The Dispensary Facility will trim all trees, bushes and other foliage around the Dispensary Facility to ensure that no one can conceal themselves from the security camera view. The Dispensary Facility will plant aggressive foliage, such as thorn bushes and holly, under all windows and around the perimeter to deter concealment.

Steel bollards will be installed in front of the entrances if permissible to prevent a vehicle from driving or smashing through doors.

Main Entry (Common)

The general public will be required to enter the Dispensary Facility through the front Main Entry. During non-working hours, entrances to and exits from the Dispensary Facility will be securely locked.

The Main Entry will be alarmed and secured against entrance or breakage. The Main Entry will have controlled access via proximity card technology. The entrances will be on a metal frame, the locks will be shielded with metal plates to prevent manipulation from the outside, and hinges will be on the interior of the door to prevent forced entry.

At least one video surveillance camera will be easily visible from the inside and outside and pointed directly at the door in such a way as to capture clear and certain identification of any person entering or exiting the Dispensary Facility. This strategy is also used to alert anyone entering the Dispensary Facility that there is an active video surveillance system, deterring potential theft.

Outdoor Signage and Public View

The public view of the Dispensary Facility will reflect its secure status without drawing attention to the fact it provides marijuana. The Dispensary Facility will post signs informing individuals of

the surveillance system in conspicuous locations. The signs will be a minimum of 12 inches in height and 12 inches in width in lettering no smaller than ½ inch in height:

*“NOTICE: VIDEO SURVEILLANCE IS IN USE ON THESE PREMISES.
AVISO: LA VIGILANCIA VÍDEO ESTÁ EN USO EN ESTOS LOCALES.”*

The Dispensary Facility will also conspicuously post signs informing individuals that all safes have a time delay. Since time delays are effective at reducing robbery losses, this notice is intended to deter criminals from attempting an armed robbery.

The Dispensary Facility will ensure at all times that all marijuana will not be visible from the exterior of the building.

Premises Management

The Dispensary Facility considers itself part of the community and, as such, will always maintain and clean the grounds around the perimeter to ensure good standing locally. The perimeter will be designed and maintained with the goal to prevent theft and diversion of marijuana.

To reduce theft, loss, and diversion, all areas of the Dispensary Facility premises will be maintained free of debris and kept clean and orderly.

- Trash will be properly removed from the Secured Storage Vault.
- Floors, walls, and ceilings will be kept in good repair at all times.
- Graffiti will be removed within 24 hours of discovery.

A checklist will be made of any maintenance activity, cleaning, sanitization, or inspection of any of these activities. This checklist will be kept in the appropriate physical or electronic file for a period of at least three (3) years. The checklist will be reviewed each week by Dispensary Facility Management to identify and correct any concerns about maintenance.

All areas, including the Dispensary Department, will be maintained with adequate lighting, ventilation, temperature, sanitation, humidity, space, equipment and security conditions for the sale of marijuana products.

In accordance with Sec. 21a-408-37, if the Dispensary Facility is unattended for any amount of time, the Dispensary will take measures to ensure that adequate security of the Dispensary Department is provided and that entry by unauthorized persons is prevented or immediately detected. Otherwise, the Dispensary Department during these times will be considered to have adequate security. In addition, if no such Dispensary technician is available for this purpose, and the Dispensary Department is not within the view of the Dispensary, the Dispensary will physically or electronically secure the Dispensary department through the use of mechanisms such as a locked barrier or an alarm system that will prevent or immediately detect access to such department.

Parking

Dispensary Facility Employees may only park in the areas designated for Dispensary Facility employee parking. Dispensary Facility Employee parking will be separate from visitor parking. Dispensary Facility Employees may only be on the premises during scheduled shifts. The Dispensary Facility will prevent Dispensary Facility Employees and individuals from remaining on the premises if they are not engaging in an activity permitted by the Regulations of Connecticut State Agencies.

Emergency Vehicles/Services Access

Emergency vehicles will have full access to the premises to provide adequate emergency vehicle access, (Fire, Police, Ambulance), and to give the best possible emergency response time. Fire lanes will be installed and maintained in accordance with the fire codes of the city.

A KNOX-BOX Rapid Entry System safe box will be wall-mounted at the front entrance and will hold building keys and/or proximity cards for fire departments, emergency medical services, and police to retrieve in emergency situations. The local fire companies will hold master keys and/or access cards to all boxes in their response area so that they can quickly enter the premises without having to force entry or find individual keys held in deposit at the station.

ACCESS CONTROL

The Dispensary Facility is not open to the general public and will take proactive measures to prevent unauthorized access into and throughout the premises. The Chief Security Officer will lead efforts to ensure that access is not inappropriately or unnecessarily authorized and ultimately lead the elements of the security plan that regulate access in its deterrence of theft, loss, or diversion of marijuana or other valuable assets. Access is restricted unless explicitly granted.

Access Authorization (Determination and Management)

Access to different rooms in the Dispensary Facility will be physically regulated by a centralized security system that determines who can enter a room. Only Dispensary Facility Employees will be given key cards that open doors after tapping the card against a reader. All card readings will be recorded, then approved or denied.

The Dispensary Facility will utilize a proximity access key card (key card) system to regulate access throughout the Dispensary Facility. The system is managed at the individual cardholder level and at any point the Chief Security Officer will be able to disable access to the cardholder or restrict their access based on a schedule. The system will also report attempts by individuals to utilize their card when it has been disabled. Security measures such as key cards, passwords, and pin codes will not be accessible to persons other than specifically authorized Dispensary Facility employees per Sec. 21a-408-51(a)(7).

The Dispensary Facility will maintain all security system equipment and video surveillance systems in a secure locked closet only accessible through the Security/Surveillance Room so as to prevent theft, loss, destruction, or alterations and will not use the cabinets for any other

purpose or function. The Dispensary Facility will limit access to security equipment to Dispensary Facility Employees that are essential to surveillance operations, law enforcement agencies, security system service employees, the DCP Commissioner or their authorized representative, and others authorized by the commissioner in accordance with 21a-408-62(d). The Dispensary Facility will make available a current list of authorized Dispensary Facility employees and service employees that have access to the Security/ surveillance room or equipment to the commissioner or their authorized representative upon request.

The Dispensary Facility will keep all onsite surveillance rooms, such as the Security/Surveillance Room, locked and will not use such rooms for any other function.

Access Control Entry Points

Qualifying patients and primary caregivers will not have unrestricted access to pass throughout the Dispensary Facility. A defined access control entry point serves to regulate the flow of individuals by requiring them to pass through an identified door to reach certain areas. This door will be monitored by alarms and video systems to detect and identify individuals entering or exiting the restricted area.

Access to qualifying patients and primary caregivers can be described by three levels of secured access:

- Common Access – Only includes the Check-In Area, Waiting Room, and Restrooms. Once admitted into the Dispensary Facility, individuals have access to these areas.
- Limited Access – Only includes the Dispensary Department and the Private Consultation Room. Qualifying patients and primary caregivers may gain access upon approval and under supervision of a Dispensary Facility employee.
- Restricted Access – The rest of the Dispensary Facility. Qualifying patients and primary caregivers are restricted from entering these areas. Only visitors and employees authorized to enter such areas may gain access. Access to one restricted area does not guarantee access to the entire Dispensary Facility.

Upon a Dispensary Facility Employee granting permission, qualifying patients and primary caregivers will have “limited access” in the Dispensary Facility to enter the Dispensary Department to complete transactions. Qualifying patients and primary caregivers will enter from the Waiting Room.

To separate the Dispensary Facility into levels of secured access, the Dispensary Facility will establish an interior access control entry point between the Dispensary Department and the restricted access areas. This point separates the “restricted access” area from common and limited access areas. Restricted access areas will only be accessible to Dispensary Facility Employees requiring such access to perform functions and access may be scheduled; otherwise, the Dispensary Department will be securely locked and protected from entry by unauthorized employees per Sec. 21a-408-51(a)(8).

The exterior door adjacent to the Receiving Area will be monitored by the video and alarm system to ensure only authorized Producer delivery team members and authorized Dispensary

Facility employees involved in receiving shipments have access. The general public, qualifying patients or primary caregivers will not be permitted to enter this door.

Hardware overview

The Applicant will utilize a proximity access key card (key card) system to regulate access throughout the Dispensary Facility:

- Each Dispensary Facility Employee will be given a key card that will be printed by the Dispensary Facility Management onsite.
- Key cards will contain the Dispensary Facility Employee's picture, name, position, and a unique serial number associated with the Dispensary Facility Employee.
- Dispensary Facility Employees must visibly wear their key card on their person at all times while at the Dispensary Facility and must take their key card home.
- Any lost or stolen access key card must be reported to the Chief Security Officer and Dispensary Facility Management immediately.

The key card permits or denies access through a doorway:

- An individual taps the keycard against a proximity access reader.
- The reader checks the individual's key card against the system database of permitted entry.
- If the database does not include that individual having access through that doorway at that moment, the door will not unlock.
- If the database does include that individual having access through that doorway at that moment, the door may unlock if a key card is all that is required for entry.
- More secure rooms may then require a second form of verification, such as entering a pin code or a biometric reading.
 - The individual must comply with the request for a pin code or biometric reading in order to gain access.
 - If the second form of verification complies with requirements in the database, access will be granted.
 - If the second form of verification does not comply with requirements in the database, access will be denied

An electronic log of Dispensary Facility employees, pin codes, and their associated key card serial numbers will be kept on file for at least three (3) years. The Dispensary Facility will maintain an electronic backup system for all access code and electronic records. Dispensary Facility Employees must visibly wear their key card on their person at all times while at the Dispensary Facility and will take their key card home. Any lost or stolen access key card must be reported to the Chief Security Officer and Dispensary Facility Management immediately.

The Dispensary Facility's alarm system also works with the key card to promote accountability and tracking. Every time a Dispensary Facility Employee uses a key card and/or pin number to enter an area, the Dispensary Facility's alarm system will electronically record and maintain the Dispensary Facility Employee's information, the time and date the Dispensary Facility Employee entered the room, and how long the Dispensary Facility Employee was in the room. The alarm

and access control systems will flag any time a door is left open for longer than ten seconds. A log of all entries into restricted rooms will be maintained with the security records.

Doors that do not require an access control system will have door key locks.

Two factor Authentication

Areas that require higher security, such as rooms storing surveillance system equipment, will only be accessible by providing at least two inputs of authorization, such that a stolen key card will not be enough to grant access.

The access control entry points and secured areas will be equipped with a commercial grade combination proximity reader and pin code reader. Authorized individuals will present their proximity access control card at the proximity reader and enter their pin. If they are currently authorized to enter, then the locking device at the entry point will be released. Only those Dispensary Facility Employees with a need to access particular areas of the Dispensary Facility will be given the necessary authorization.

Because there is a potential for unauthorized personnel to discover the pin code of the keypad, the combination will be changed at irregular intervals not to exceed 90 days. All Dispensary Facility Employees will also be given a duress pin code that they can enter into the keypad, which will signal to local law enforcement in an emergency situation per 21a-408-62(a)(5).

There will be a mechanical override available where required and the emergency keys to override the locking mechanism will be “high security” keys and codes to prevent duplication. Emergency keys will only be distributed to Dispensary Facility Management or responding emergency personnel. Only Dispensary Facility Employees will be given access cards and be authorized in the system. Only those Dispensary Facility Employees with a need to access certain areas of the Dispensary Facility will be given the necessary access.

The Dispensary Facility will not allow keys to be left in locks and will not allow keycards or keys to be stored or left in a location accessible to persons other than specifically authorized employees per Sec. 21a-408-51(a)(6).

Doors and Door locks

As doors and locks are the primary control against unauthorized access to restricted areas, the Dispensary Facility will secure all doors and maintain them to ensure that they continue to function optimally. All exterior doors and windows will be alarmed and secured against covert entrance or breakage. Locks will be kept in good working order per Sec. 21a-408-51(a)(5).

The Dispensary Facility will only install commercial grade, non-residential security doors on every access-controlled external door to the facility. The Dispensary Facility will securely lock the Dispensary Facility, including all interior rooms, with commercial-grade, nonresidential door locks.

Entrances/exits and doors to higher-security areas will be protected by 16-gauge steel security doors that are rated for 60-minutes forced entry resistance. These doors will be on a metal frame, locks will be shielded with metal plates to prevent manipulation from the outside, and hinges will be on the interior of the door to prevent forced entry. Doors will remain closed and locked at all times when not immediately being used to enter or exit the area.

Exterior locks will be shielded with metal plates to prevent manipulation from the outside.

The Dispensary Facility will use electric strike locks at the Dispensary Facility. Electric strike locks enable easier access control modification and are less susceptible to damage than physical locks. Electric strike locks utilize electric pulses from a low-voltage source to indicate a door should open. Instead of turning a key in a core to remove a lock, the pulse activates an actuator that removes the lock. Where permissible, locks will be fail secure, meaning a power failure will not automatically release door locks during a power outage. This will include the Secure Storage Vault.

Fire Exits

All fire exit doors that are not used for regular business operations will use an emergency door lock system that will provide access control as well as being fire-rated. Emergency doors will feature maximum protection against prying attempts at the lock edge of the door. Emergency doors will be bolted to the frame at multiple locations and will project stainless-steel bolts deep into the door frame. Emergency doors will also feature a fire-code compliant single-motion egress. Fire exits will be constructed so that the path to egress is obvious and direct, and fire exit doors will swing open in the direction of egress.

Employee Access Policies and Procedures

The Dispensary Facility will implement policies that control the actions of its Dispensary Facility employees and ensure that its Dispensary Facility employees only enter areas to which they have specific authorized access. Dispensary Facility Employees will utilize their key cards to gain access to different parts of the Dispensary Facility. Access permission to more sensitive rooms will be dependent on their role and will be determined by the Chief Security Officer and Dispensary. ID badges visible to other individuals and the surveillance system will be used to hold Dispensary Facility employees accountable when they attempt to access a room.

Per Section 21a-408-51(a), the Dispensary Facility will:

- Maintain all marijuana in a secure area or location accessible only to specifically authorized Dispensary Facility employees, which will include only the minimum number of Dispensary Facility employees essential for efficient operation.
- Keep all approved safes and approved vaults securely locked and protected from entry, except for the actual time required to remove or replace marijuana.
- Not allow keys to be left in the locks and not store or place keys in a location accessible to persons other than specifically authorized Dispensary Facility employees.
- Not allow other security measures, such as combination numbers, passwords or electronic or biometric security systems, to be accessible to persons other than specifically authorized Dispensary Facility employees.

- Keep the Dispensary Department securely locked and protected from entry by unauthorized Dispensary Facility employees.

Entrance and Exit Policy

Dispensary Facility Employees will enter and exit the Dispensary Facility through the public Main Entry unless required for an authorized task. Dispensary Facility Employees will not be permitted on the premises outside of work hours. Where applicable, Dispensary Facility Employees will be required to scan their key card at each door each time they pass through the doorway.

Security/Surveillance Room

Per Section 21a-408-62(d), the Dispensary Facility will limit access to surveillance areas to persons that are essential to surveillance operations, law enforcement agencies, security system service employees, the commissioner or the commissioner's authorized representative, and others when approved by the commissioner. The Dispensary Facility will make available a current list of authorized Dispensary Facility Employees that have access to the Security/surveillance room to the commissioner or the commissioner's authorized representative upon request. The Dispensary Facility will keep all on-site Security/surveillance rooms locked and will not use such rooms for any other function.

Access to the security equipment and computer will be password protected. Dispensary Facility Management will be required to safeguard this password by keeping it confidential and not writing it down in an area that could be accessed by others. All security system equipment and recordings will be maintained in good working order.

At the Dispensary Facility the Dispensary Facility Manager will designate and train Dispensary Facility Employees to monitor the security systems and surveillance system. This monitoring Dispensary Facility Employee on duty will communicate to the Chief Security Officer or Dispensary Facility Management any unusual occurrences.

Secure Storage Vault Access

The Dispensary Facility storage policies are designed to ensure that all marijuana is secure and safe from theft and diversion. Marijuana not being sold will be secured in a safe located in the Secured Storage Vault per Sec. 21a-408-51(a)(2).

This storage policy will include any time the Dispensary Facility is not opened for business. Areas containing inventory of marijuana will be restricted to and scheduled for only those Dispensary Facility Employees who require access per Sec. 21a-408-51(a)(3). The Dispensary Facility will not store marijuana in excess of the quantity required for normal, efficient operation per Sec. 21a-408-51(a)(1). Safes will remain locked and protected from entry except when marijuana is removed or replaced per Sec. 21a-408-51(a)(4).

The GSA Class 5 rated vault door with two-factor authentication via a commercial grade combination/pin code reader will be the only access point into the vault. Authorized individuals will have to enter their personalized security pin code as well as use the combination lock to

open the safe. If they are currently authorized to enter the secured room, then the pin code locking device of the vault door will be released.

- Only those Dispensary Facility employees with a need to access the Secured Storage Vault will be given the necessary authorization.
- Because there is a potential for unauthorized personnel to discover the combination to the Secure Storage vault door the combination will be changed at irregular intervals not to exceed 90 days.
- All Dispensary Facility employees will also be given a duress pin code that they may enter into the vault keypad; this duress pin code will signal to local law enforcement of an emergency situation but still open the safe.
- A log of all entries and code changes into a Secured Storage Vault will be maintained with the security records for three (3) years.

ID Badge Policy

Each Dispensary Facility Employee will wear a Dispensary Facility photo identification badge at all times while at the Dispensary Facility. All photo identification badges will be worn on breakaway style lanyards, at chest height. All photo identification badges will be placed inside a plastic transparent identification holder. Dispensary Facility Employees will be instructed that the identification holder will not have any items on or in the holder to cover any part of the issued badge.

Per Section 21a-408-34(i), all Dispensary Facility Employees will, at all times while at the Dispensary Facility, have their current Dispensary license, Dispensary Technician registration or Dispensary Facility employee registration available for inspection by the commissioner or the commissioner's authorized representative.

Visitors Policies and Procedures

By law, the Dispensary Facility will not allow visitors into the Dispensary Facility as the Dispensary Facility is not open to the public. Only in cases where a visitor is required to serve a legitimate business purpose of the Dispensary Facility, including but not limited to service providers repairing equipment or the structure of building, will the Dispensary Facility seek authorization from the commission to allow such a visitor into the Dispensary Facility. Per Section 21a-408-35(g)(1)(2), upon prior written request, the commissioner or the commissioner's authorized representative may waive the visitor prohibitions of premises access. Except when specifically allowed by the commissioner or the commissioner's authorized representative, it will be the policy of the Dispensary Facility that no person, except a Dispensary Facility employee, or a production facility employee who is delivering marijuana products, will be allowed on the premises of a Dispensary Facility without a qualifying patient or primary caregiver registration certificate issued by the department. Sec. 21a 408-35(f).

Once a visitor is approved by the commissioner or the commissioner's authorized representative,, the Dispensary Facility will require visitors to record their visit into a log and obtain a badge for identification. All persons not permitted on the premises of a Dispensary Facility per 21a-408-35(f), but who have been authorized, in writing, to enter the facility by the commissioner or the commissioner's authorized representative will obtain a visitor identification

badge from a Dispensary Facility employee, prior to entering the Dispensary Facility. Visitors will always be escorted by a Dispensary Facility employee. A person who is not a holder of a valid Dispensary Facility Employee identification card of the Company is prohibited from accessing any restricted area of the Dispensary Facility unless they receive authorization and obtain a visitor identification badge from the Dispensary Facility.

Individuals requesting a visitor identification badge will approach the reception area where qualifying patients and primary caregivers enter. ID and appropriate registration will be verified by senior management and/or security.

In order to obtain a visitor identification badge per Sec 21a-408-35(g)(2)(3), a visitor must provide a valid government-issued identification which must contain their name, photograph, and date of birth. Visitors will be signed into a visitor log, which will include the following information:

- Full name of each unregistered visitor entering the regulated premises.
- Department, Company, or other entity associated with visitor's access.
- Badge number.
- Purpose of visit.
- Areas of the Dispensary Facility visited.
- The assigned registered Dispensary Facility Employee who is escorting the visitor.
- Date of arrival.
- Time of arrival.
- Signature of visitor upon arrival.

A person who obtains a visitor badge will do the following:

- Be escorted and monitored by an assigned registered Dispensary Facility Employee at all times they are on the premises and have access to marijuana.
- Visibly display their visitor identification badge at all times when in the Dispensary Department.
- Return the visitor's identification badge to a Dispensary Facility Employee upon leaving the premises.
- Enter the time of departure into the log upon leaving the premises.

Upon departure the visitor will return the visitor's identification badge to the Dispensary Facility and sign out of the visitor's log by writing their time of departure and signing their name. The visitor's log will be available for inspection at all times. The visitor log will be maintained for at least three (3) years and made available to the DCP, local law enforcement, and other state or local government officials upon request if necessary to perform the government functions and duties.

Per Sec. 21a-408-35(g)(4), if an emergency requires the presence of a visitor and makes it impractical for the Dispensary Facility to obtain a waiver from the commissioner or their authorized representative, the Dispensary Facility will provide written notice to the commissioner as soon as practicable after the onset of the emergency. This notice will include

the name and company affiliation of the visitor, the purpose of the visit, and the date and time of the visit. The Dispensary Facility will monitor the visitor and maintain a log of such a visit.

Per Section 21a-408-35(j), members of the department, local law enforcement or other federal, state of Connecticut or local government officials may enter any area of a Dispensary Facility if necessary to perform their governmental duties.

Qualifying Patient and Primary Caregiver Policies and Procedures

Qualifying patients and primary caregivers will only be permitted into the Waiting Room, Private Consultation Room, and Dispensary Department. Access will only be granted after permission from a Dispensary Facility Employee. All doorways into the rooms, as well as the rooms themselves, will be monitored not only by Dispensary Facility Employees but also by security systems to detect and identify individuals entering or exiting the Restricted Area.

When in the Consultation Room or in the Dispensary Department, Qualifying patients, and primary caregivers requiring access to restrooms will be escorted by a Dispensary Facility employee. These individuals will then be immediately escorted back to areas where they have been granted access. Individuals with no access to any region of the Dispensary Facility will not be permitted access to the restrooms.

Qualifying Patients and Primary Caregivers at Dispensary Facility Entrance

All qualifying patients and primary caregivers will enter the Dispensary Facility through the Main Entry. Parking for qualifying patients and primary caregivers will be separate from Dispensary Facility employee parking. Lighting outside will be sufficient for clear and certain video identification. Video will be taken from entry and exit vantage points.

At the Check-In Area:

- The Dispensary Facility will ask the qualifying patients and primary caregivers for government-issued proof of identification (ID) and their registration certificate.
- The Dispensary Facility Employee will check that the ID matches information on the certificate and the qualifying patient or primary caregiver in front of them.
- Proof of identification must contain the individual's name, photograph, and date of birth.
- If information does not match and the qualifying patient or primary caregiver is unable to provide necessary documentation, the qualifying patient or primary caregiver will not gain entrance and will be asked to leave until obtaining such documentation.
- Qualifying patients and primary caregivers will state whether they request private consultation or not unless it is their initial visit.
- If the ID and the registration certificate confirm the validity of entry, then the qualifying patient or primary caregiver will then be permitted in the Waiting Room after completing the log and receiving their badge.

Qualifying Patient and Primary Caregivers in Waiting Room

Qualifying patients and primary caregivers will move into a warm, comfortable and inviting Waiting Room. The room will be decorated with soft colors and equipped with comfortable chairs for qualifying patients and primary caregivers to use should they have to wait any amount

of time to enter the rest of the facility. The Waiting Room will include an ADA-compliant bathroom. All bathroom doors will be wide enough for wheelchairs and persons with other walking aids (such as walkers) to enter and exit with ease. The Waiting Room will be large enough to seat people comfortably and will contain commission pre-approved medical marijuana educational materials. It is not anticipated that there will be a lot of “waiting” in the Waiting Room as the Dispensary will encourage qualifying patients to schedule appointments, over the phone or through its on-line scheduling tool, in advance to cut down on wait times for walk-ins and to increase the efficiency of the Dispensary in serving the qualifying patient community.

Qualifying Patients and Primary Caregivers in Private Consultation Room

Escorted by an employee and upon permission from that employee, a qualifying patient or primary caregiver will be able to go into the private qualifying patient consulting room to meet with a Dispensary.

Qualifying Patients and Primary Caregivers into Dispensary Department

The Dispensary Facility’s aim is to provide a safe and secure environment for qualifying patients and primary caregivers who choose to visit the Dispensary Facility. The Dispensary Facility plans to accomplish this goal by providing strict procedures that will prevent anyone from gaining access to the Dispensary Department who is not authorized and will prevent anyone from being present at the Dispensary Facility who does not have a valid reason for being there.

Per Section 21a-408-34(h), the Dispensary Facility will not permit any person to enter the Dispensary Department unless:

- Such person is licensed or registered by the Department of Consumer Protection.
- Such person’s responsibilities necessitate access to the Dispensary Department and then for only as long as necessary to perform the person’s job duties.
- Such person has a qualifying patient or primary caregiver registration certificate, in which case such person will not be permitted behind the service counter or in other areas where marijuana is stored.

Per Section 21a-408-35(a), the Dispensary Department will not be open or in operation, and no person will be in the Dispensary Department, unless a Dispensary is on the premises and directly supervising the activity within the Dispensary Department. At all other times, the Dispensary Department will be closed and properly secured, in accordance with Sections 21a-408-51 and 21a-408-62.

Qualifying patients and primary caregivers will have “limited access” in the Dispensary Facility to, upon a Dispensary Facility Employee granting permission, enter the Dispensary Department to complete transactions.

- Qualifying patients and primary caregivers will enter from the Waiting Room.
- Qualifying patients and primary caregivers requesting a private consultation will wait for and, from then on, be escorted into the Dispensary Department by a Dispensary or Dispensary Technician.
- Qualifying patient records will be retrieved using an electronic data storage system.
- The registration certificate of the qualifying patient or primary caregiver will be verified.

- The Dispensary or Dispensary Technician consulting with the qualifying patient or primary caregiver will also handle any transactions in conjunction with the cash management plan.

At all times, the Dispensary Facility will use a one-to-one qualifying patient to Dispensary Facility employee ratio in the Dispensary Department. No qualifying patient or primary caregiver will be allowed into the Dispensary Department unless there are at least 2 Dispensary Facility employees in the Dispensary facility available to provide consultation and assist the qualifying patient or primary caregiver in obtaining marijuana.

Transaction Procedures to Regulate Access:

- A Dispensary, or Dispensary Technician, will require the presentation of a registration certificate together with another valid photographic identification issued to a qualifying patient or primary caregiver, prior to selling marijuana to such qualifying patient or primary caregiver per Sec. 21a-408-38(f).
- Per Section 21a-408-35(c), no marijuana will be consumed on the premises of a Dispensary Facility. Dispensaries and Dispensary Technicians will inform qualifying patients and primary caregivers of this rule prior to sale of marijuana. Any individuals, including qualifying patients, doing so will be escorted off the premises and subject to legal action.
- Dispensaries and Dispensary Technicians will ensure the transaction is appropriately logged in the Inventory Control System and other business systems.
- Upon completing a transaction, qualifying patients and primary caregivers will be instructed to leave the Dispensary Facility premises. Qualifying patients and primary caregivers will exit the Dispensary Department back into the Waiting Room, not through any other doorway.
- Dispensary Facility Management or security personnel will monitor the qualifying patients and ensure that they leave the parking lot of within 10 minutes after exiting the Dispensary Facility.

The Dispensary Department will be securely locked and protected from entry by unauthorized Dispensary Facility employees per Sec. 21a-408-51(a)(8).

- Attempts to access areas outside of scheduled hours will be logged accordingly in the security system.
- Access will only be granted outside of scheduled hours if an individual enters a duress code or another form of alarm that overrides access denial.
- All video of failed access attempts will be stored for at least 30 days or longer pending investigation in conjunction with the Applicant's video storage policy.

Per Section 21a-408-36, during such times that the Dispensary Department is closed:

- It will be securely locked and equipped with an alarm system.
- Such alarm will be activated and operated separately from any other alarm system at the Dispensary Facility and will be able to immediately detect entrance to the Dispensary Department at times when it is closed.

- Keys and access codes to the alarm system will be controlled in such a manner so as to prevent access to the Dispensary Department by other than authorized Dispensary Facility Employees.
- Only a Dispensary will have the authority to deactivate the alarm system.
- A Dispensary Facility will store marijuana in an approved safe or approved vault within the Dispensary Department and will not sell marijuana products.

During times that the Dispensary Department is closed, the Dispensary Facility will ensure that the Facility is securely locked and the specific alarm system for the closed Dispensary Facility is armed in accordance with Sec. 21a-408-36 (a):

- The alarm will be activated and operated separately from any other alarm system at the Dispensary Facility and will be able to immediately detect entrance to the Dispensary Department at times when it is closed.
- Keys and access codes to the alarm system will be controlled in such a manner so as to prevent access to the Dispensary Department by other than authorized Dispensary Facility Employees.
- Only a Dispensary will have the authority to deactivate the alarm system.
- The alarm system will be able to be accessed remotely by the Dispensary and will send alerts immediately to the Dispensary to alert them of any attempted access to the Dispensary Facility.

During the times that the Dispensary Department is closed for momentary absences of a Dispensary, the Dispensary will take steps to ensure that there are adequate security measures in place per Sec. 21a-408-37.

VIDEO MONITORING SYSTEM

A video surveillance system enables the clear recording of events at a particular location. As a business that needs to maintain the utmost standards of security, the Dispensary Facility will use its video surveillance system to record all marijuana movement, sales, Dispensary Facility employees, and visitors to ensure that no marijuana can be diverted or stolen. With the cameras in place, any potential events that involve security issues can be easily recognized and remedied.

Purposes/Intent

The Dispensary Facility will implement a video surveillance system, utilizing commercial grade equipment installed in a manner that will prevent cameras from being readily obstructed, tampered with, or disabled. This system is designed to detect diversion, theft, or loss of marijuana and capture clear and certain identification of all persons in or around the Dispensary Facility.

Safety and security purposes for the surveillance system include but are not limited to:

- Protection of individuals, including Dispensary Facility Employees, visitors, and qualifying patients and primary caregivers.
- Protection of property, marijuana, building perimeter, entrances and exits, lobbies and corridors, receiving areas, and storage areas.

- Verification of alarms and electronic security systems.
- Video patrol of restricted areas.
- Deterrence of criminal activity.
- Investigation of criminal activity and disciplinary activity.

The Dispensary Facility will use a professionally monitored, sophisticated high-definition video surveillance system that records all activity in images capable of clearly revealing details including:

- Dispensary Facility Employee and visitor ID badges.
- Facial features and tattoos for identification.
- Vehicle license plates.

A live video feed will also be remotely accessible for local law enforcement, the Chief Security Officer and Dispensary Facility Management, and the DCP. This live video feed will also allow emergency dispatchers to remotely access video, providing first responders better situational awareness when responding to emergencies.

Camera Placement

The cameras for the Dispensary Facility will be placed in specific locations that will be able to execute the clear recording of all relevant events and locations. The Dispensary Facility will use line-of-sight camera placement at the Dispensary Facility, which will be capable of clearly revealing facial detail and identifying all persons on the premises under not only normal, but all, lighting conditions in and around the following in accordance with Sec. 21a-408-62(a)(3):

- All points of entry and exit of the Dispensary Facility.
- All dispensing areas of the Dispensary Department.
- All loading areas.
- All exterior sides of the building adjacent to the public rights of way.
- The perimeter of the building, including parking areas.
- All approved safes.
- The Secure Storage Vault.
- Each area used for marijuana sales for the clear and certain identification of each Dispensary Facility Employee dispensing marijuana and any qualifying patients and primary caregivers purchasing marijuana, as well as the sale, the individuals, and the computer monitor used for the sale.
- Any other area where marijuana is stored or handled.

All cameras will be installed at a height that provides an optimal vantage point to allow clear and certain identification of all individuals and activities in and around the premises. This coverage will include all entrances and exits from both indoor and outdoor points. The system will operate under not only normal but all lighting conditions for each area. The surveillance system cameras can identify persons, license plates, vehicles, and activities within any area of the premises and within twenty (20) feet of all entry and exit points to and from the premises.

The Dispensary Facility will maintain and update a map of the camera and alarm locations, the direction of coverage, camera numbers, security equipment maintenance activity log, user

authorization list, and operating instructions for the camera equipment. This documentation and map will be kept in the Security/Surveillance Room and will be updated whenever a camera's location is changed.

Camera Features

The Dispensary Facility will install advanced commercial cameras that will enable clear and certain identification.

Internet Protocol (IP) cameras are digital video cameras commonly employed for surveillance; unlike analog television cameras, IP cameras can send and receive data video via a local computer network and the Internet. The Dispensary Facility will utilize bullet cameras and dome cameras that meet the descriptions below. Bullet cameras are more common for security, but dome cameras will also be used to enable a wider field of view per camera and to prevent tampering. Features of IP Cameras will include the following:

- At least 1920 x 1080p (2 Megapixel or MP) Resolution – Resolution describes the total number and orientation of tiny dots that create the larger picture. In this case, the image will have 1920 single color dots in a horizontal row crossed with 1080 dots in a vertical column to create a matrix of over 2 million individual dots.
- Up to 180-degree field of view – In certain areas of the Dispensary Facility, it is easier and more informative to observe a larger area in one image rather than break up a view into multiple smaller regions from different cameras. These cameras will require (and typically have) higher resolutions such as 4 MP to provide comparable pixel density.
- At least 1/3" CMOS sensor – Larger sensors absorb more light per pixel, enabling better color depth and light sensitivity.
- At least 10 Frames per Second (FPS) – FPS is the frequency (rate) at which an imaging device captures consecutive images called frames.
- Progressive scanning – Reduces flickering by capturing an entire image at once, as opposed to interlacing
- Data will be transmitted over the Real-time Protocol (RTP) or Real Time Streaming Protocol (RTSP).
- Camera feed will traverse the IP network from the camera source to the server, utilizing Motion JPEG (MJPEG) or MPEG-4/H.264/Advanced Video Coding codec technology.
- Infrared capability – camera will utilize the infrared spectrum to improve contrasting, especially for facial recognition, to improve low-light situations or day/night adjustments.

All cameras will be calibrated and focused to maximize the quality of the recorded image. All cameras will be installed at a height that provides an optimal vantage point to allow a clear image of all individuals and activities in and around the Dispensary Facility. This coverage will include all entrances and exits to the Dispensary Facility from both indoor and outdoor points.

The system will operate under not only normal but all lighting conditions for each area. The surveillance system cameras can identify persons, license plates, vehicles, and activities within any area of the Dispensary Facility and within twenty (20) feet of all entry and exit points to and from the premises. Motion-activated lighting will be installed to increase picture clarity and brightness and ensure proper surveillance during hours of darkness at all entry points, low light interior areas, and where all exterior cameras are located.

Outdoor cameras will have at least an IP66-rating to withstand rain and dust.

Video Management System/Embedded Network Video Recorder

The Dispensary Facility will use an Internet-accessible video recorder to optimize its surveillance security.

The Dispensary Facility will install a multi-channel Internet Protocol (IP) embedded network video recorder (ENVR) which functions as the security system's central hub. The ENVR records video from multiple cameras in a digital format to a disk drive, USB flash drive, SD memory card, or other mass storage device. The ENVR will be remotely accessible at all times through a secure web portal for Dispensary Facility Management, the DCP, and local law enforcement. Remote accessibility will permit Dispensary Facility Management, the DCP, and local law enforcement to view live footage and review security logs from the Dispensary Facility at any time. Direct feed and login capabilities will be provided to the DCP and local law enforcement to allow for real-time access and monitoring. This will allow the DCP and local law enforcement to verify at will that the Dispensary Facility is following all applicable security and procedural requirements.

Cameras in the Main Entry will record individuals every time they enter and leave the Dispensary Facility, and the ENVR will take photos from these recordings so that up-to-date photos of employees, visitors, and qualifying patients and primary caregivers are maintained. The video system will produce a clear, color, still image in a digital format and clearly display the time and date on the video.

In accordance with Sec. 21a-408-62(a)(11)(12), a date and time stamp will be embedded on all recordings and will be synchronized, set correctly, will not significantly obscure the picture, and will have the ability to remain operational during a power outage. The date and time will synchronize with the official United States time established by the National Institute of Standards and Technology and the U.S. Naval Observatory.

Per 21a-408-62(a)(10) the Dispensary Facility will also utilize a color printer capable of immediately printing clear color still photos at a minimum of 9600 dpi from any camera image live or recorded.

Per 21a-408-62(f) the ENVR allows the export of still clear color digital images in industry-standard image formats, including .jpg, .bmp, and .gif. The ENVR will automatically archive exported surveillance footage in a proprietary format that ensures authentication of the video and guarantees that no alteration of the recorded image has taken place. The exported footage is archived in an industry-standard file format that can be viewed on a standard computer operating system. The Dispensary Facility will ensure all recordings are erased prior to disposal or sale of the Dispensary Facility.

Even though the ENVR will automatically store all recordings and electronic security logs, this information is also backed up and stored on a cloud-based server. The video surveillance system will have the ability to record all images captured by each surveillance camera for a minimum of

thirty (30) days in a format that will be easily accessible for investigative purposes. Surveillance video will record 24 hours per day, 7 days per week. Video storage will be kept in a locked cabinet within the Security/Surveillance Room with access limited to authorized personnel, law enforcement agencies, security system service employees, and DCP. Recordings from all video cameras will be made available for immediately viewing by the commissioner or the commissioner's authorized representative upon request. Sec. 21a-408-62(a)(4).

Storage of Video Recordings

As many areas and events will be recorded, the Dispensary Facility foresees the need for extensive video storage.

The video surveillance system will use removable hard-drives rack-mountable servers for extensive video storage. Software access controls and logs will protect the system from unauthorized tampering and allow Dispensary Facility Management review of all system access and access attempts. The system will store video clips using several proprietary derivative compressed video formats which cannot be edited or altered.

Video compression makes it ideal for remote video transmission over affordable broadband. Efficient video compression also allows the same number of days of video storage in less than half the hard drive space required by other video storage systems.

Utilizing a redundant array of independent disks (RAID) is a way of storing the same data in different places on multiple hard disks to protect data in the case of a drive failure. RAID systems are thus more reliable for accessing and retrieving video recordings in storage.

The video recordings will also be sent electronically to an off-site cloud-based storage site. The amount of storage needed for both the Embedded Network Video Recorder (ENVR) device and cloud system will depend on various factors such as the number of cameras needed, megapixels of the camera, and frame rate.

Security Systems Equipment

The Dispensary Facility will store its surveillance system equipment in a manner and location to prevent tampering and restrict access. The security system equipment such as the ENVR will be installed in a secure cabinet in the Security/Surveillance Room to prevent theft, loss, destruction, or alterations per 21a-408-62(b). The Security/Surveillance Room will also house the following:

- 24" call-up monitors connected to the electronic recording security system at all times.
- A computer (one call-up monitor may double as the computer monitor).
- A color printer capable of immediately producing a clear color still photo that is a minimum of 9600 dpi from any camera image (live or recorded).
- Video playback equipment.
- A master intercom.
- A phone.
- An alarm panic button.
- A lockable case for portable equipment.

Access to the security equipment and passwords will be limited to Dispensary Facility Employees that are essential to surveillance operations, law enforcement, security system service employees, or DCP authorized representatives. Access to the security equipment and computer will be password protected. Dispensary Facility Management will be required to safeguard this password by keeping it confidential and not writing it down in an area that could be accessed by others. All security system equipment and recordings will be maintained in good working order.

At the Dispensary Facility the Dispensary Facility will designate and train a Dispensary Facility Employee(s) to monitor the security systems and surveillance system. This monitoring Dispensary Facility Employee on duty will communicate to the Director of Security or Dispensary Facility Management any unusual occurrences.

Surveillance Recordings

The surveillance recordings will be created, collected, and stored in a manner that will enable the Dispensary Facility to readily access the recordings and ensure their accuracy. The ENVR records and archives video surveillance from a network of cameras in a proprietary digital format to a hard drive. The ENVR ensures authentication of the video and that no alteration of the recorded image has taken place.

The exported video surveillance recordings will be kept at the Dispensary Facility in a locked cabinet, closet, or another secure place to protect the recordings from tampering or theft. The exported video surveillance recordings will also be backed up offsite via cloud-based storage. The room will have restricted access to Dispensary Facility Employees identified to the DCP and will be secured by a security alarm system separate from the site's primary security system.

In addition to the 24-hour live feed with motion-activated recordings from all video cameras, the Dispensary Facility will retain the recordings for a minimum of thirty (30) days, unless a recording is needed for a longer period per 21a-408-62(a)(4). If the Dispensary Facility is aware of a pending criminal, civil or administrative investigation or legal process for which a surveillance video recording may contain relevant information, the Dispensary Facility will retain an unaltered copy of the recording until the investigation or proceeding is closed or the entity conducting the investigation or proceeding notifies that it is no longer necessary to retain the video recording.

The Dispensary Facility will make recordings available to local law enforcement, and DCP. The Dispensary Facility will be able to produce a digital video disk using an installed media recording drive that provides video viewable on any operating system. Recordings will be archived in an industry-standard file format that can be viewed on a standard computer operating system. The archived exported surveillance footage will be in a proprietary format that ensures authentication of the video and guarantees that no alteration of the recording has taken place. After the surveillance video retention schedule has lapsed, surveillance video recordings will be erased or destroyed prior to being discarded or disposed of for any other reason.

Inspections and Repair

The Dispensary Facility will maintain the surveillance system in a manner that will enable it to be inspected and repaired whenever necessary. The Dispensary Facility will keep all video surveillance, access control, and alarm security systems in good working order 24 hours a day, 7 days a week per Sec. 21a-408-51(a)(5). The security systems will be inspected, and all devices tested at least twice a year by a qualified security consultant per 21a-408-62(g). For inspection:

- The Dispensary Facility will conduct an internal maintenance inspection once a month and ensure that all necessary repairs, alterations, and upgrades are made for the proper operation of the systems.
- The Dispensary Facility will keep a maintenance activity log which will include:
 - The identity of the individual performing the service
 - The service date and time
 - The reason for the service to the systems
- The Dispensary Facility will retain at the Dispensary Facility, for at least three (3) years, a maintenance activity log of all inspections, servicing, alterations, and upgrades performed on the system.

The maintenance activity records will be made available upon request to the local municipality and DCP.

The Dispensary Facility will install a failure notification system that provides an audible, text or visual notification of any failure in the surveillance system. The failure notification system will provide an alert to Dispensary Facility Management within 5 minutes of the failure, either by telephone, email, or text message.

In the event of a prolonged failure of the surveillance system, the Dispensary Facility will take steps to ensure theft and diversion techniques are mitigated by other means.

Back-up Power Source for Video Surveillance

To prepare for a power outage in accordance with 21a-408-62(a)(12), the Dispensary Facility will contract with a licensed power source company to purchase the appropriate backup power source system which will maintain normal video surveillance activity for up to 48 hours. The video surveillance systems will be equipped with an uninterruptible power supply (UPS) synchronized with a compatible high-output generator to provide a seamless transition from main power to auxiliary power in the event of a power outage. In the event of a system failure, an immediate alert will be provided via email, phone, and text message to Dispensary Facility Management by the system.

ALARM SYSTEM

Intrusion Detection Overview

The Dispensary Facility will contract with a third-party company to handle the 24/7 live alarm monitoring of the Dispensary Facility. The alarm system will utilize commercial grade equipment to prevent and detect diversion, theft, or loss of marijuana. In addition, a private security company will respond to every alarm.

The Dispensary Facility will install alarms in accordance with Sec. 21a-408-62, which includes the following:

- A perimeter alarm system primarily governed by motion detectors to detect intrusion into the Dispensary Facility.
- Duress alarms to silently indicate a user is entering a code to disarm the security system.
- Panic alarm buttons to signal a life-threatening or emergency situation requiring a law enforcement response.
- Hold-up alarms to silently indicate a robbery-in-progress by pressing a button.
- Glass break detectors to monitor the breakage of windows.
- Door contacts to indicate when an access-controlled door is opened.

Per 21a-408-62(a)(8) the Dispensary Facility will be equipped with a radio automatic voice dialer which, when activated, will send a prerecorded voice message requesting dispatch to the central station alarm company and law enforcement. Per 21a-408-62(a)(9) the alarm system will also have a failure notification system that provides an audible, text and email notification within five (5) minutes of any system failure. In the event of a system failure, an immediate alert will be provided via email and text message to Dispensary Facility Management. In the event of an extended mechanical malfunction of the surveillance or alarm system, The Dispensary Facility will notify local law enforcement and the DCP. A power failure will not release electronic door locks during a power outage.

The alarm system will at least cover the following areas:

- All points of ingress and egress, such as doorways, windows, or skylights.
- Any rooms with exterior walls.
- Rooms with exterior windows.
- Any rooms containing a safe.
- Any rooms where marijuana is sold or stored.
- The perimeter.

If any alarm incident, Dispensary Facility Management will make a record of the following to be stored for at least three (3) years:

- The date and time of the occurrence.
- Measures taken in response to it.
- Date and time when the measures were taken.

In accordance with Sec. 21a-408-36(a), when the Dispensary Facility is closed, it will be securely locked and armed with an alarm. This alarm will be activated and operated separately from any other alarm system at the Dispensary Facility and will be able to immediately detect entrance to the closed Dispensary Department. Keys and access codes to the alarm system will be controlled to only permit authorized access. Only a Dispensary will have the authority to deactivate the alarm system.

Alarm Equipment

The alarm equipment of the alarm system will be more than sufficient to protect against breach of security.

The alarm control panel directs the flow of signal data between the sensors and the recipients, including the surveillance areas, the alarm company, and applicable government ministries.

The Dispensary Facility will be using an alarm control panel to send alarm signals and upload/download via Internet Protocol. The control panel will send a signal or polling to the alarm company every 200 seconds to ensure the system is in good working order and transmitting to the alarm company.

To turn the alarm system on or off, the Dispensary Facility will be governed by an alarm keypad equipped with a duress code in accordance with 21a-408-62(a)(5). This code will allow the user to transmit a silent signal to the alarm company indicating that the user is being forced to turn off the alarm system. A duress alarm will also be activated by the two-factor access authentication system described in the Access Control section, e.g. entering a specific “duress” pin code.

Per Sec. 21a-408-62(a)(2), the Dispensary Facility will be using passive infrared (PIR) motion detector to guard the perimeter rooms. Motion detector sensors in the Dispensary Facility that will alert authorities if there is an attempted break-in through the roof, windows, or walls. The Dispensary Facility will have a perimeter alarm with alarm contacts on all Dispensary Facility entry and exit points, windows with exterior walls, rooms that contain safes, and the perimeter of the Dispensary Facility.

The Dispensary Facility plans to use door contact transmitters to monitor when doors are opened. Most door contact sensors utilize a circuit with magnetic contacts and a low current. When the door is closed, the contacts touch and create a “closed” circuit with a low current. When the door opens, the contacts no longer touch and create an “open” circuit through which a current cannot flow.

The Dispensary Facility will be using a glass break detector on any exterior glass. These detector sensors will alert authorities of an attempted break-in through glass windows. Glass detectors can be mounted on any wall or ceiling within a normally 25-foot range of a window.

Per 21a-408-62(a)(7) the Dispensary Facility will also utilize a silent alarm, known as a holdup alarm button or duress alarm, generated by the manual activation of the device, which is intended to signal a robbery in progress to the alarm company and local law enforcement. Alarm buttons are activated by pressing the device button; and once activated, they cannot be deactivated.

Per 21a-408-62(a)(6) emergency remote panic alarm button pendant transmitters will be worn by all Dispensary Facility Employees at the Dispensary Facility. Once activated by pressing the button on the unit, the panic alarm will signal an audible alarm that notifies the public safety answering point for the law enforcement agency having primary jurisdiction. This device is intended to be used to signal a life-threatening or emergency situation that would require an

urgent law enforcement response. The system will also have an automatic voice dialer that will send a prerecorded voice message requesting dispatch, when activated, over a telephone line and radio to law enforcement and emergency services.

Inspection and Repair

To ensure all video surveillance, access control, and alarm security systems are operating in good working order per Sec. 21a-408-51(a)(5), the security systems will be inspected, and all devices tested twice every year by a qualified third-party security system vendor per 21a-408-62(g). The Dispensary Facility will conduct an internal maintenance inspection once a month and ensure that all necessary repairs, alterations, and upgrades are made for the proper operation of the systems. The Dispensary Facility will keep a maintenance activity log which will include the identity of the individual performing the service, the service date and time, and the reason for the service to the systems.

The Dispensary Facility will retain at the Dispensary Facility, for at least three (3) years, a maintenance activity log of all inspections, servicing, alterations, and upgrades performed on the system. The maintenance activity records will be made available upon request to the DCP and its authorized agents.

Power Source

To prepare for an outage in accordance with 21a-408-62(a)(12), The Dispensary Facility will contract with a licensed power source company to purchase the appropriate backup power source system which will maintain normal security alarm system activity for up to 48 hours. The alarm systems will be equipped with an uninterruptible power supply (UPS) synchronized with a compatible high-output generator to provide a seamless transition from main power to auxiliary power in the event of a power outage.

Fire Alarm

To prepare against a fire, the alarm system will have a robust smoke and fire alarm, and auxiliary power sufficient to video surveillance and alarm systems for at least 48 hours. The Dispensary Facility will comply with all local and provincial building laws and fire codes. Dispensary Facility Management will closely monitor updates to the fire code regulations to ensure full compliance.

If a single smoke detector activates, a Dispensary Facility Employee must investigate the area where the unit is located to determine the reason for activation. If no fire is located, the smoke detector will be inspected for functionality. If multiple smoke detectors sound, all persons must evacuate the building in accordance with the emergency procedures described later. Dispensary Facility Management will be responsible for contacting the local fire department and all persons will be required to wait outside at a safe distance from the building until the fire department provides further direction. Fire extinguishers will be strategically located throughout the building and available for those with proper fire safety training to put out a small fire.

The fire alarm will be tested in conjunction with the local fire department to ensure its operation. The Dispensary Facility will also establish a line of communication with the local fire department and other regulatory authorities to identify and comply with signage requirements.

RECEIVING

The Dispensary Facility's protocols for receiving marijuana shipments will guarantee safe and efficient transfer of marijuana. The Dispensary Facility's procedures for receiving shipments enable its employees to transport marijuana safely and quickly from the transport vehicles to secured storage. These procedures and protocols will minimize any potential for diversion of marijuana, loss of marijuana, or mistake in shipment details.

Authorized Personnel and Equipment Checks Prior to Delivery

A Dispensary Facility Manager, Dispensary, or Dispensary Technician, who is registered with the State of Connecticut and specifically authorized to access the Dispensary Facility safe or vault, will verify that the safe codes are known and have not been changed, the safes and vault door can be opened and closed without incident, and there are no obstructions in place between the delivery vehicle parking area and Secure Storage Vault. Having a clear path from the Receiving Area to the Secured Storage Vault will protect against possible accidents that could jeopardize the safe and exact transfer of the marijuana. The Dispensary Facility Manager will ensure that the delivery area is neat, clean and free of any other debris or material from prior deliveries.

The Dispensary Facility Manager, a Dispensary or a Dispensary Technician will be notified of a pending delivery and will be on hand and available.

Restricted Access to the Delivery Space

The Dispensary Facility Management will designate an area restricted to delivery vehicles. This space will be in the nearest possible proximity to the exterior door used for receiving. Access to the delivery space will be limited to the Producer team delivering the marijuana and authorized Dispensary Facility Employees. All authorized Dispensary Facility Employees will have security training relevant to receiving shipments.

Prior to allowing the Producer team to enter the Dispensary Facility, a Dispensary the will ensure that each person present is identified by an identification card or badge per Sec. 21a-408-34(j) and Sec. 21a-408-25, by signature log if applicable, and clearly under video surveillance, and is necessary for the successful receiving of the delivery. The Dispensary Facility will not allow access to the Dispensary Facility unless two authorized Dispensary Facility Employees are present. If the above-referenced processes reveal no threats and 100% compliance, the delivery shall proceed.

Security and Surveillance Prior to Delivery

The Producer transportation vehicle will arrive at the Dispensary under direct video surveillance that covers all approach routes to the facility per Sec. 21a-408-62(a)(3)(4). A Dispensary Facility Employee will remotely monitor the vehicle as it arrives. The Dispensary Facility will require

that a Dispensary is notified by the Producer delivery team at least 15 minutes prior to leaving the Producer for any delivery of marijuana. Upon notification, a Dispensary Facility Employee will verify functionality of the access control devices and video cameras around entry and exit point to determine the video feeds are clear, and the video resolution is more-than-sufficient to produce a clear color still photo (9600 dpi) which can determine personnel features per Sec. 21a-408-62(a)(3)(10).

A Dispensary Facility Employee will also monitor the Dispensary Facility premises and all neighboring areas for individuals conducting surveillance, suspicious vehicles, or any other irregularity inside or outside the dispensary. The Dispensary Facility Employee will verify video for the correct date and time stamps per Sec. 21a-408-62(a)(11), outside lighting is functional and no bulbs are burnt out, and all security systems are in good working order.

It is an authorized Dispensary Facility Employee's responsibility to perform a threat assessment prior to delivery, and as the delivery arrives. All Dispensary Facility Managers, Dispensaries, and Dispensary Technicians will be trained to detect threats and suspicious activities on or around the premises. If a Dispensary Facility Employee perceives a threat and believes the Dispensary Facility to be in imminent danger, the Dispensary Facility Employee will initiate a lockdown of the Dispensary Facility and immediately notify the local police of the perceived threat. The Dispensary Facility Employee will also notify the Producer delivery team and instruct them to abort the delivery. If no threat is perceived, the scheduled delivery will be allowed to proceed.

In the event that the Producer delivery team has to make an unforeseen stop, the Dispensary Facility will require that the delivery team immediately alert the Dispensary Facility, and the delivery will be aborted. Law enforcement will be notified in the event of theft, attempted theft, carjacking, and accident, or other situations in which the delivery vehicle may hold shipments of marijuana for an extended time. In the event that the Dispensary Facility is contacted by Producer regarding criminal activity that is in progress, the Dispensary Facility will alert the police department to make certain that the police department is informed and up to date on the situation.

Delivery Team Verification

Before the Producer's delivery team members are allowed to access the receiving area of the Dispensary Facility, they will sign in to the authorized visitor log book and their identities will be confirmed by a Dispensary. This confirmation will consist of multiple stages:

- As the Producer delivery team arrives at the Dispensary Facility, the Producer team will call the Dispensary and confirm their names, Producer association, and vehicle make and license plate number.
- The Dispensary Facility will also confirm visually by camera surveillance that the information received by the phone call matches the images on the surveillance screen.
- Once this information has been confirmed by phone, the ID will be verified against the manifest at the reception area in accordance with the visitor policy.
- Once confirmed by the Dispensary Facility, the Producer employees who will enter the Dispensary Facility during the transfer will be required to sign the visitor log and will

receive a Dispensary Facility-issued visitor badge to wear throughout the remaining delivery process.

One delivery team member must remain in the vehicle at all times and in accordance with all safety precautions mandated by Sec. 21a-408-60(f).

All authorized Dispensary Facility Employees involved in the delivery will be wearing badges, which will allow them to clearly identify themselves to the Producer delivery drivers per Sec. 21a-408-25(a)(b)(c). The Producer will be made aware of authorized Dispensary Facility Employees who will assist with delivery and will make the Dispensary Facility aware of the identities of the Producer delivery team. These practices will help safeguard the potential for diversion of marijuana by confirming with the Producer's employees exactly who will be handling the received shipment at the Dispensary Facility.

Per Section 21a-408-60(h), a Producer delivery team member will possess a department-issued identification card at all times when transporting or delivering marijuana and will produce it to the commissioner, the commissioner's authorized representative or law enforcement official upon request. Delivery team members will be instructed to follow the Dispensary Facility's visitor policy.

Security and Surveillance During the Receiving Process

The Dispensary Facility will implement innovative methods to ensure the safe and secure delivery of marijuana into the Dispensary Facility. To safeguard against any loss or diversion of shipments, video surveillance will record all areas including the parking lot and exterior door associated with receiving product and moving it into secure storage. An authorized Dispensary Facility Employee will always accompany the Producer delivery team member that is loading product into the Dispensary Facility. Per Section 21a-408-34(q), all deliveries from Producers will be carried out under the direct supervision of a Dispensary who will be present to accept the delivery. Upon delivery, the marijuana will immediately be placed in an approved safe or approved vault within the Secure Storage Vault where marijuana is stored.

The Dispensary Facility will monitor surveillance before arrival of the shipment and during shipment to look for suspicious persons or activity. If such suspicious persons or activity are noticed before receiving begins, the Dispensary Facility will immediately contact the Producer and instruct them to abort the shipment. Any individuals not associated with the delivery team or Dispensary Facility will be asked to leave the immediate area. The Dispensary Facility will also ensure that an authorized employee is adjacent to a panic or hold-up alarm button(s) and instructed to activate the alarm in case of emergency.

The Dispensary Facility will create standard operating procedures for its Dispensary Facility employees to address various issues that can arrive during the receiving process. Among the issues that will be covered in the standard operating procedures will be attempted theft during the receiving process and packaging malfunction that leads to spillage of the marijuana product.

Receiving shipments of marijuana will only occur during normal business hours, but scheduled shipments will not be scheduled for regular, recurring times and dates so that a pattern may not be noticed or established.

Safe and Secure Storage

After receipt, the product will be immediately placed into the Secured Storage Vault in the restricted access area. Per Section 21a-408-51(a)(2)(3)(4)(5), the Dispensary Facility will:

- Store all marijuana in an approved safe or approved vault and in such a manner as to prevent diversion, theft or loss.
- Maintain all marijuana in a secure area or location accessible only to specifically authorized Dispensary Facility Employees, which will include only the minimum number of employees essential for efficient operation.
- Keep all approved safes and approved vaults securely locked and protected from entry, except for the actual time required to remove or replace marijuana.
- Keep all locks and security equipment in good working order.

Access to any Dispensary Facility area containing marijuana will be identified via a sign stating, “Do Not Enter – Limited Access Area – Access Limited to Authorized Employees Only” in lettering a minimum of twelve inches in height and twelve inches in width per Section 21a-408-51(a)(9).

The Secure Storage Vault, at all times, will be dry, well-lit, ventilated through an odor control filter system. Moreover, all medical marijuana will be stored at temperatures and under lighting conditions that will ensure the integrity of marijuana prior to removal from the Secure Storage Vault.

On a routine basis, the Secure Storage Vault and all physical inventory management items will be cleaned and sanitized to prevent the buildup of debris and residues that may compromise product integrity or attract insects, rodents or other pests. The walls and floors of the vault will be sealed for ease of cleaning, and any physical inventory management items will be constructed in such a manner that allows them to be easily cleaned and sanitized.

Manifest Verification

Prior to transportation, the Dispensary Facility will have received the commissioner-approved shipping manifest form, which was transmitted at least 24 hours prior to the transport date mutually agreed to per Sec. 21a-408-60(a). The Dispensary Facility Employee who is to receive the shipment will confirm with the Producer, prior to delivery, that the Dispensary Facility has received the shipping manifest. Once the authorized parties enter the Dispensary Facility, the Dispensary Facility Employee in charge of receiving operations will have a transport manifest that lists each item expected for delivery and a checklist that outlines each of the state-mandated labeling and packaging requirements per Sec. 21a-408-60(b).

The Dispensary Facility will require that the Dispensary Facility Manager or a Dispensary review the manifest before the Producer's delivery team embarks on the delivery. It will be the

responsibility of the Dispensary Facility Manager or Dispensary to rectify any discrepancy between the order and the shipping manifest before the delivery takes place.

During delivery intake, Dispensary Facility Manager or a Dispensary will ensure the following of the products contained in the shipment:

- Meets all state packaging and labeling requirements.
- Is not expired.
- Is free from damage.
- Is not deteriorated or been adulterated.
- Is the correct count per the manifest.
- Possesses correct dispensary name listed on the product label.

Any product that does not meet the state labeling or packaging requirements per Sec. 21a-408-56 or is expired, damaged, deteriorated, misbranded or adulterated in any way will be rejected by the Dispensary Facility and sent back to the Producer.

Any item missing from the shipping manifest, and the delivery, will be noted as a discrepancy and reported appropriately per Sec. 21a-408-63(b). It will be the policy of the Dispensary Facility to treat any missing marijuana as a potential attempt at diversion. Therefore, the authorized Dispensary Facility Employee will note the missing item, and alert law enforcement authorities and the Drug Control Division of the department within 24 hours of the event.

Per Sec. 21a-408-60(b), the Dispensary Facility will maintain all shipping manifests and make them available in accordance with Sec. 21a-408-70 of the Regulations of Connecticut State Agencies.

Inventory Control System Data Entry

Dispensary Facility Employees present at the delivery will be responsible for ensuring an accurate record of the items received and that all items are entered into the inventory control system. They will also be responsible for reporting variances in accordance with Sec. 21a-408-63(b). After a visual confirmation is made that all products have been delivered matching the shipping manifest and that Producer labels are securely affixed in accordance with Sec. 21a-408-56, the Dispensary Facility Employee, while in the presence of a second Dispensary Facility Employee, will place a unique dispensary identification barcode sticker on the item and the item will be logged into the inventory tracking system. No delivery will be complete until each item is verified by at least two employees and entered into the system. Dispensary Facility Employees will use commercial barcode and/or RFID scanners to facilitate data entry, limit errors, and prevent subversion of marijuana products.

Many inventory control programs are flexible with respect to data entry; still, the Dispensary Facility will choose an Inventory Control System that promotes ease of use along with versatile tools and stringent compliance. The precise quantity of units, type, producer product code, strain

and batch ordered will be entered. That Dispensary will verify that all received products will have a label securely affixed to the package, which states in English the name and address of the producer along with brand name of the product, and the date of expiration among other Producer label requirements in accordance with Sec. 21a-408-56(a)(c). Dispensary Facility Employees responsible for receiving will record each product into expiration date logs to ensure the product does not expire at the Dispensary Facility.

Once each week, the Dispensary Facility Manager will reference the expiration logs to see if a product is due to expire in the next thirty (30) days. Any product set to expire in thirty (30) days will be identified and tracked separately to ensure the product is sold before expiration. If the product expires, it will be destroyed in accordance with Sec. 21a-408-64.

The tracking control system will be a necessary safeguard to prevent diversion of marijuana and inaccurate inventory records. On the day of the delivery, Dispensary Facility Management not directly involved in the receiving process from that day's delivery will review the records of the shipment entered into the inventory control tracking system and will double check the physical inventory to confirm that the records match the inventory. These additional steps will guard against missing inventory as any discrepancy between physical inventory and the inventory record will be identified the same day as the shipment. All shipping manifests will be available to authorized parties for three (3) years in accordance with 21a-408-70.

STORAGE

The Dispensary Facility's goal will be to secure marijuana in an area that cannot be accessed except by authorized individuals. To achieve this goal, the Dispensary Facility will install a Secured Storage Vault. By storing marijuana in this Secured Storage Vault, theft and diversion will be prevented; and all stored marijuana will be easily accounted for.

Secure Storage Vault

The Dispensary Facility's storage policies are designed to ensure that all marijuana is secure and safe from theft and diversion. Marijuana not being sold will be secured in a safe located in the Secured Storage Vault per Sec. 21a-408-51(a)(2).

This storage policy will include any time the Dispensary Facility is not opened for business. Areas containing inventory of marijuana will be restricted to and scheduled for specifically authorized Dispensary Facility Employees, which will only include the minimum number essential for efficient operation per Sec. 21a-408-51(a)(3). The Dispensary Facility will not store marijuana in excess of the quantity required for normal, efficient operation per Sec. 21a-408-51(a)(1). Safes will remain locked and protected from entry except when marijuana is removed or replaced per Sec. 21a-408-51(a)(4).

All marijuana marijuana will be kept in at least a 30-minute Underwriters Laboratory Approved Tool and Lock rated safe (TL-30).

There will be at a minimum at least three 30-minute Underwriters Laboratory Approved Tool and Lock rated safes housed in the Dispensary Facility Secure Storage Vault.

All marijuana that requires refrigeration will be kept in a refrigerator unit that is inside the Secured Storage Vault. The door of the refrigeration unit will be secured and protected from being compromised via a pry security device. The temperature will be set to maintain the highest integrity of the marijuana at all times and controlled by a temperature alert system connected to the central alarm system.

Secure Storage Vault Construction

The Secure Storage Vault will be designed to ensure that all marijuana that is stored within will be guarded against any attempt of theft.

The Secure Storage Vault will be constructed with concrete masonry units (CMU) on all walls and the floor in accordance with Sec. 21a-262-1(g)(1). CMU is made of concrete blocks with concrete tie beams and reinforced vertically and horizontally with ½ inch steel rod rebar tied 6 inches on center for added security. The interior of the walls will be lined in heavy duty, 1/4" thick wire metal mesh to increase security. This thick wire mesh has 3" square grids and will be mounted both vertically and horizontally to fit all parts of the interior of the wall. The wire metal mesh will then be covered with 3/4" plywood to add additional security and also allow for shelving inside the secured room. The ceiling of the Secure Storage Vault will be constructed of modular vault panels composed of ultra-high strength concrete core with formed steel panels. Ventilation ports will be designed into the ceiling to facilitate climate control, ensuring an optimal storage environment.

Per Sec. 21a-262-1(g)(4), the walls, floor, and ceiling of the vault will be equipped with an alarm which, when unauthorized entry is attempted, transmits a signal directly to a central station protection company, or a local or state police agency which has a legal responsibility to respond, or a 24-hour control station operated by the registrant. Holdup buttons will be placed at strategic points of entry to the perimeter area of the vault, such as near the vault door. Vault walls will be monitored by the alarm system via electrical lacing, ultrasonic sensors, a sensitive sound accumulator system, or a similar system to detect illegal entry per Sec. 21a-262-1(g)(6). The electrical alarm system will be certified as being an Underwriters Laboratories, Inc., approved system and installation per Sec. 21a-262-1(g)(7).

Vault Door

The Dispensary Facility's Secure Storage Vault door will be designed to guard against forced entry to ensure that marijuana is guarded against theft.

The Secure Storage Vault will only be accessible through a GSA Class 5 or similar vault door in compliance with 21a-262-1(g)(2)(4). The vault door will have an opening size of at least 40" wide x 78" high (if single door) with 1/2" Plate Steel, multiple bolt locking system, Underwriters Laboratory Group 1 lock, and a dual re-locker to prevent bolt retraction during an attack. The vault door will also be connected to the alarm system via a contact switch.

The commercial grade GSA Class 5 vault door with two-factor authentication via a commercial grade combination/pin code reader will be the only access point into the Secure Storage Vault. Authorized individuals will have to enter their personalized security pin code as well as used the combination lock to open the safe. If they are currently authorized to enter the secured room, then the pin code locking device of the vault door will be released.

Only the minimum number of Dispensary Facility employees with a need to access the Secure Storage Vault of the Dispensary Facility will be given the necessary authorization per Sec. 21a-408-51(a)(7). Because there is a potential for unauthorized personnel to discover the combination to the Secure Storage Vault door the combination will be changed at irregular intervals not to exceed 90 days.

The Dispensary Facility will install a second form of verification such as a pin code reader for its utility in duress situations. Employees will be given a duress pin code that they may enter into the vault keypad; this duress pin code will signal to local law enforcement of an emergency situation but still open the door. A log of all entries and code changes into a Secure Storage Vault will be maintained with the security records for three (3) years.

An emergency ventilator and “pass through” will accommodate air flow or allow anyone inside to safely exit in case the door closes. The “pass through” will work even in a fail-secure environment, which would prevent entry in the event of a power outage.

To ensure the integrity of inventory, the Dispensary Facility plans to use a day gate to keep the vault door unlocked during business hours per Sec. 21a-262-1(g)(3). Inventory will, as much as possible, be transferred to display cases when the Dispensary Department is closed to qualifying patients and primary caregivers; however, the day gate will facilitate frequent access. The vault door will be self-closing and self-locking or equivalent.

Safes

To store marijuana in the Secure Storage Vault, the Dispensary Facility will use advanced commercial safes that will be designed to withstand forced entry attempt. All marijuana will be secured and stored in a 30-minute or more Underwriters Laboratory Approved (UL) Tool and Lock rated safe (TL-30) with an Underwriters Laboratory 5-minute time delay Group 1 outside lock.

A TL-30 safe is the standard safe used in most high-risk industries such as the jewelry, firearms and the pawn industries. An Underwriters Laboratory Approved Tool and Lock Safe offers much more security and protection than a standard gun safe model or non-rated safe because of its superior design and construction. Safes assigned an Underwriters Laboratory Tool and Lock 30 rating have all passed standardized tests defined in Underwriters Laboratories Standard 687 using the same tools and usually the same group of testing engineers. Underwriters Laboratory requires that the safe is constructed of 1-inch solid steel or equivalent. The rating means that the safe has been tested for a networking time of 30 minutes of attack using “common hand tools, drills, punches hammers, and pressure applying devices.” Networking time means simply “when

the tool comes off the safe the clock stops.” There are over 50 different types of attacks that might be used to break into this safe, such as using picking tools and hand tools, mechanical or electrical tools, grinding points, carbide drills, pressure applying devices, cutting wheels, power saws and impact tools. Any safe used to store marijuana will be at least an Underwriters Laboratory Approved Tool and Lock 30 rated safe or higher with a 5-minute time delay outside lock.

Safes will satisfy all requirements of Section 21a-262-1(f). A TL-30 is rated four classes higher than a B burglary rating and most, if not all, have multiple internal relocking devices to prevent bolts from retracting during an attack. Safes will weigh at least 750 lbs. or be securely anchored (often with bolts) to a permanent structure of the building. Safes will have adequate interior space to store all marijuana.

Safe door locks

All of the storage safes for marijuana will also use Underwriters Laboratory Group 1 outside combination and pin code locks to secure the safe door. An Underwriters Laboratory Group 1 combination lock is resistant to skilled manipulation attacks for up to 20 hours. A manipulation attack is any attempt to discern the combination on the lock using the features and weaknesses in the design of the lock. An example of a manipulation attack can be seen in a movie in which a safecracker attempts to listen to the safe lock (possibly with a stethoscope) to learn the combination. In addition, any attempt to randomly or systematically explore the namespace of combinations (the allowed range of possible combinations) is also a manipulation attack. The Group 1 lock is a very advanced mechanical lock that is precisely designed to prevent the workings of the lock from revealing the combination. These locks are only used on the highest rated and most advanced safes.

This integration of the combination lock and a pin code lock will offer additional protection against attacks by mechanical, electrical, and cutting tools. All safe locks will also be installed with a 5-minute time delay before unlocking the safe to increase the length of time needed to open the safe. It has been shown in many high-risk businesses that this time delay is very effective in reducing losses should a break-in or armed robbery occur.

CASH PLAN

Cash is currently the most popular method of payment for transactions involving marijuana. Steps will be taken to ensure that the cash is handled properly and that criminals do not target the Dispensary Facility and Dispensary Facility Employees for their cash inventory in addition to their marijuana product inventory. Additionally, cash will be monitored to guard against employee theft and diversion practices.

Cash Protocols Inside the Dispensary Facility

The Dispensary Facility’s cash protocols will ensure that cash is always securely handled. A Dispensary Facility Employee serving qualifying patients and primary caregivers will also act as a cashier to make the transaction a smooth and streamlined experience. The Dispensary Facility Employee will print an invoice for the product purchased and any related items to facilitate the

delivery of the product being purchased. Every transaction will be recorded by the POS inventory control system.

Upon completing a transaction, qualifying patients will leave the Dispensary Facility. Dispensary Facility Management or security personnel will monitor the qualifying patients and primary caregivers and ensure that they leave the parking lot of within 10 minutes after exiting the Dispensary Facility. Under no circumstance may qualifying patients and primary caregivers consume marijuana products at the Dispensary Facility per Sec. 21a-408-35(c).

All cash transactions and cash counting must be conducted within full view of a security camera. These counts include:

- Beginning of day starting cash.
- End of day balancing of cash drawers.
- Final counting, sorting and stacking by a manager before the cash is deposited in the cash safe located in the Manager's Office.
- Periodic counts at a manager's discretion.

Cash revenues will be removed from the register and drop safe daily and placed in the main cash safe located in the Vault after the Dispensary Facility has closed. Dispensary Facility Management will maintain two-person verification by supervising the daily deposit of revenues into the cash safe. All counts of cash in drawers during the day are to be written down in a log and signed by the Dispensary Facility Employees who must each log their final totals and sign their names in the log.

Cashier Accountability

The Dispensary Facility will ensure that its employees are trained to handle cash transactions and accountable for their register. Each Dispensary Facility Employee handling cash for the Dispensary Facility will be trained in efficient and safe cash management techniques. Each employee engaged in actual sales to qualifying patients and primary caregivers will be assigned an individual cash drawer. A secure drop safe will be located under the counter at the service windows and employees will be required to make periodic cash drops into the drop safe each time the contents of their cash drawers exceed \$500. Cash drawers may never be left open or unattended, and employees will not openly handle large amounts of cash in the presence of qualifying patients and primary caregivers.

All Dispensary Facility Employees will be held strictly accountable for the balance of their drawers periodically during working hours and at the close of each day. If an employee does not balance within one percent (1%) of perfect on three occasions, that employee may be terminated or removed from any position involving the handling of funds. All funds remaining in cash drawers and all funds in the drop safe will be deposited into the main safe at the close business each day as described above.

From time to time, Dispensary Facility Management will conduct unscheduled spot checks or audits of Dispensary Facility Employees who handle cash. These actions may include, but are not limited to:

- Intentionally overloading an employee starting cash amount by a known amount and ensuring that there is an equivalent overage when cash is counted later in the day.
- Conducting surprise, unscheduled counts.

Cash Protocols for Transporting and Depositing

The Dispensary Facility may contract with a bank or third-party security company that utilizes an armored vehicle, or comparable secured transportation, to transport cash deposits from the Dispensary Facility to its bank. In such case, Dispensary Facility Management will order cash pickups at periodic, alternating intervals.

Prior to cash pickups, under the supervision of Dispensary Facility Management, a Dispensary Facility Employee will:

- Count and sign the safe log for all outgoing deposits.
- Utilize dual-pouch, tamper-resistant depository bags.
- Write the deposit information in the space provided on the outside of each depository bag.
- Record the number of bags and each unique bags number on a deposit ticket and retain a copy of the deposit ticket for records.
- Seal all depository bags.

During cash pickups, under the supervision of Dispensary Facility Management, a Dispensary Facility Employee will:

- Verify the armored truck guard's identification badge.
- Record the package quantity being shipped.
- Ensure that all guards where a name tag and are escorted by a Dispensary Facility Employee at all times, they are within the Dispensary Facility. All other rules regarding visitors will be followed at all times.

All cash transactions and cash counting must be conducted within full view of a security camera. From time to time, Dispensary Facility Management will conduct unscheduled spot checks or audits of cash in the safe.

INFORMATION SECURITY

The Dispensary Facility desires to avoid exposing itself and Dispensary Facility Employees from illegal or damaging actions through computer use. The Dispensary Facility owns all computers and systems used in the Dispensary Facility for business operations. Acceptable use of electronic resources, including computers, networks, cell/smart phones, PDA's, e-mail, and electronic information sources at the Dispensary Facility, protect the employee and the Dispensary Facility. Inappropriate use exposes the Dispensary Facility to risks including virus attacks, compromise of network systems and services, legal, and ethical issues.

The Dispensary Facility will ensure compliance with the Health Insurance Portability and Accountability Act ("HIPAA") by training all staff on the relevant HIPAA requirements. Per

Section 21a-408-49(a), for the storage and retrieval of qualifying patient information or other marijuana records, the Dispensary Facility will use a system that:

- Guarantees the confidentiality of the information contained therein.
- Is capable of providing safeguards against erasures and unauthorized changes in data after the information has been entered and verified by the Dispensary.
- Is capable of being reconstructed in the event of a computer malfunction or accident resulting in the destruction of the data bank.

All Dispensary Facility records will be maintained in an electronic format, encrypted and backed up off-site. All records shall be kept in a locked, restricted access area when not in use. The Dispensary Facility shall set levels of restriction for certain records. For example, only certain Dispensary Facility Employees shall have access to records involving personnel and incidents/investigations at the Dispensary Facility. Levels of access shall be maintained by using information technology platforms to restrict certain employees from access to all records.

The Dispensary Facility's information and cyber security program will engage a wide range of strategies, tactics and tools including:

- Security packages verifying user sign-on to computers, log recordings, and password verifications, which change on a set pattern.
- Strengthen domain and network security, establish strong password policies, create a regular patching routine, and segment networks.
- Conduct once a year third-party vulnerability hacking tests checking for weaknesses in the system.
- Online security software conducting periodic scans, virus checks, elimination of malware, Trojan horses, and attempts at hacking into the system.
- Hidden naming convention for the wireless system. Hackers cannot see the system.
- Automatic backup on all files into a secured section of the cloud
- Documented policies on information security and IT-related issues such as password protocols;
- Restricted and limited access of key personnel to a mobile access application;
- Employee training, awareness initiatives and risk-generated alerts on time-sensitive threats;
- Annually renewed employee acknowledgements on the use of the electronic systems within the Dispensary Facility.

This program will deter cyber-attacks and intrusions into the company's systems and prevent theft of digital records per Sec. 21a-408-33(a).

Computer Policy

In addition to the system hardware and software, all electronic files and electronic messages are the property of the Dispensary Facility. All computers are set up with sufficient software to perform normal business functions. Internet/Intranet/Extranet-related systems, including but not limited to computer equipment, software, operating systems, storage media, network accounts providing electronic mail, web browsing, and FTP, and all work product created on the Dispensary Facility computers and equipment, or by its Dispensary Facility Employees in the

course of their employment, are the property of the Dispensary Facility. These systems are to be used for business purposes in serving the interests of the Dispensary Facility, and of our clients in the course of normal operations.

Dispensary Facility Employees are responsible for the reasonable care of these items and may not install computer software on any computer without prior permission from the Dispensary Facility. Dispensary Facility Employees have no expectation of privacy on the Dispensary Facility computer systems, and the Dispensary Facility reserves the right to monitor the use of all company computer systems, e-mail systems and the internet, at any time without seeking the permission of the Dispensary Facility Employee.

Password Policy

As passwords are used to access equipment such as the ENVR or records system, they form an integral piece of the information security of the Dispensary Facility. Passwords used for computers and other equipment on the premises will not be written down, sent via email, or shared on the phone, and passwords will not be provided to individuals who do not require them. All passwords will be changed at least every 90 days and will not match the previous 10 passwords. All access attempts whether successful or unsuccessful will be logged for three (3) years.

Dispensary Facility Employees will have unique passwords to identify the user accessing the system. Passwords that are no longer needed for whatever reason will be deleted or disabled immediately. Remote access will only be permitted through a Virtual Private Network or with advanced authentication such as biometric scanning.

Internet and Email

Dispensary Facility Employees may not access the internet or use the Dispensary Facility computers or e-mail accounts for non-business use at any time. Any violation of this e-mail or internet policy may result in disciplinary action up to and including immediate termination.

Use of company-provided electronic communication tools by our Dispensary Facility Employees will be exclusively related to company business. The Dispensary Facility reserves the right to access the contents of our employees' electronic communications in the event any prohibited activities have occurred.

COMMUNITY POLICY

The Dispensary Facility aims to conduct business in a professional and respectable fashion. To reach this goal, the Dispensary Facility will ensure that it is not a burden or hindrance on the surrounding community. The Dispensary Facility will maintain regular contact with neighboring businesses and local law enforcement to develop its place in the community.

Safety Overview

The success of the Dispensary Facility depends on its Dispensary Facility Employees, qualifying patients and primary caregivers, and products. The Dispensary Facility is committed to providing

a safe and healthful workplace for all Dispensary Facility employees by establishing and maintaining an effective health and safety program.

The responsibility for safety resides within each individual. The Dispensary Facility will encourage Dispensary Facility Employees and qualifying patients and primary caregivers to stay informed and to take responsibility for their own safety as well as the safety of others. Nonetheless, employees have the greatest opportunity to develop and promote safe work habits and prevent on-the-job injury and work-related illnesses.

The Dispensary Facility promotes safety by observing the following common-sense rules:

- Learn their duties and how to be safe in the workplace on a daily basis.
- Learn the protocols for emergency situations
- Learn the location of fire alarm boxes, fire extinguishers, building exits and their individual responsibilities in case of fire.
- Promptly report all unsafe or potentially hazardous observations
- Obey all safety signs.
- Immediately report all accidents no matter how slight the incident.

Communication with Law Enforcement and Community

The Dispensary Facility will develop strong partnerships with local law enforcement agencies. These agencies may support the Dispensary Facility's security mission through collaborative training and exercises, observation patrols, responses to incidents, and proactive meetings.

The Dispensary Facility will also develop strong relationships with neighboring businesses. Neighbors are often the first to detect signs of trouble, whether from suspicious loitering Dispensary Facility Employees or criminals scouting the business. Befriending the local business community offers financial and societal benefits to the Dispensary Facility and surrounding area.

BIANNUAL REVIEW OF SECURITY POLICIES AND PROCEDURES

Security Policy and Procedures

All security policies and procedures will be reviewed biannually to ensure that they are in compliance with regulations and requirements for all applicable state agencies and adequately reflect the business policies of the Dispensary Facility.

Security Revisions

Any recommended security policy revisions or updates will be presented to Dispensary Facility Management for approval. Updated security policies will be filed in the Policy and Procedures Manual.

Security Audit

In accordance with Sec. 21a-408-62(g), the Dispensary Facility will keep all security equipment in good-working order and will test such equipment no less than two times per year. On a biannual basis, the Dispensary Facility will undergo a security risk assessment review by an outside security contractor. A security recap will be submitted to Dispensary Facility

Management no later than 30 calendar days after the review has been conducted. If the assessment identifies concerns related to security procedures of the Dispensary Facility, the security contractor will submit to Dispensary Facility Management a plan to mitigate those concerns.

February 10, 2022

VIA E-MAIL & HAND DELIVERY

Ms. Vineeta Mathur
Senior Planner
City of Stamford
888 Washington Blvd.
Stamford, CT 06901
vmathur@stamfordct.gov

**RE: Application for Special Permit Modification
Proposed “Hybrid Retailer” Cannabis Establishment
12 Research Drive, Stamford, Connecticut (the “Property”)**

Dear Ms. Mathur:

On behalf of the owner of the Property, Stamford Research Drive LLC, and tenant and operator FFD West LLC (collectively, the “Applicants”), enclosed please find application materials for the Zoning Board in connection with modifying their Special Permit for a medical marijuana dispensary (“Dispensary”) (**Appl. 221-08**) to permit a “hybrid retailer” cannabis establishment (“Hybrid Retailer”) at the Property. Pursuant to Public Act No. 21-1, a “hybrid retailer” operates as both a Dispensary and sells cannabis for adult recreational use.

The Property encompasses 27,081± SF (0.62) acres, is zoned General Industrial District (“M-G”), and is situated at the corner of Research Drive and Larkin Street in a predominantly industrial area of Glenbrook. The Property is improved with a 12,023± SF building (the “Building”) constructed in 1969. On May 3, 2021, the Zoning Board issued Special Permit and Site/Architectural Plans and Requested Uses approvals (**Appl. 221-08**) to the Applicants to operate a Dispensary in approximately 6,808± SF of the Building. For use a Hybrid Retailer, as detailed in the enclosed materials, there is no proposed increase in the retail area, and the approved sales area for the Dispensary will now provide for both medical and recreational cannabis sales. Additional details are provided within the enclosed materials.

In connection therewith, enclosed please find one (1) original, twenty (20) copies, and one (1) electronic copy of the following items (unless otherwise stated):

- Letters of Authority from the Applicants;
- A check for \$1,460.00 representing the application fees for Special Permit approval and required public hearing fee (1 original);
- Application for Approval of Special Permit;
- Schedules to Applications as follows:

- Schedule A: Property Description;
 - Schedule B: List of Plans;
 - Schedule C: Project Narrative;
 - Schedule D: Statement of Findings;
- Zoning Data Chart, dated February 10, 2022;
 - Site and Architectural Plan set prepared by L’Arc Architects LLC, dated February 9, 2022 and titled as follows:
 - A-0.1 R3.0 – “Existing Site Plan”
 - A-1.0 R3.0 – “Existing Layout Plans”
 - A-2.0 R3.0 – “Existing Exterior Elevations”
 - A-0.5 R3 – “FFD Existing ADA Plan & FFD Existing Limited Access Plan”
 - Property Survey titled “Improvement Location Survey depicting 12 Research Drive, Stamford, Connecticut,” prepared by D’Andrea Surveying & Engineering P.C., dated December 29, 2021;
 - Property aerial photo;
 - Dispensary Security Plan; and,
 - Letter from Daniel S. Glissman, Esq., dated February 10, 2022, concerning regulation of “hybrid retailers” under Public Act No. 21-1.

We look forward to presenting this project to the Zoning Board. I look forward to advice as to when the public hearing will be scheduled. If you have any questions about this application or require additional information, please do not hesitate to contact me.

Sincerely,

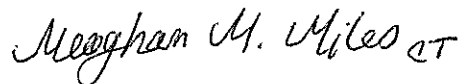

Meaghan M. Miles

Enclosures
cc: Development Team

M-G ZONING DATA CHART
12 Research Drive, Stamford, Connecticut

	STANDARD/REQUIRED	EXISTING/APPROVED	PROPOSED	NOTES
Min. Lot Area	4,000 SF	27,081 SF	Unchanged	Complies
Min. Lot Frontage	40 feet	<i>Research Drive:</i> 199.65 feet <i>Larkin Street:</i> 139.08 feet	Unchanged	Complies
FAR	1.0 (27,081 SF)	<i>Gross floor area:</i> 0.44 (12,023 SF)	Unchanged	Complies
Building Height	4 stories or 50 feet	1 story or 16.2 feet	Unchanged	Complies
Building Area (Corner Lot)	90%	44.4%	Unchanged	Complies
Min Front Yard (Street Line)	10 feet	> 10 feet	Unchanged	Complies
Min Front Yard (Street Center)	35 feet	> 35 feet	Unchanged	Complies
Min. Side Yard	None required, but if provided must be at least 4 feet	4.3 feet	Unchanged	Complies
Min. Rear Yard	15 feet	13.1 feet	Unchanged	Existing Nonconformity
Parking	<i>Retail:</i> 4 spaces / 1,000 SF (20 spaces for Dispensary) <i>Warehouse:</i> 1 spaces / 2,000 SF (3 spaces for ACME Sign Co.)	35 spaces	Unchanged	Complies